

A6V

 **华德液压**



**Axial Piston-Bent Axis Design
Variable Displacement Motor**



**斜轴式轴向柱塞
变量马达**

技 术 样 本



北京华德液压工业集团有限责任公司

BEIJING HUADE HYDRAULIC INDUSTRIAL GROUP CO.,LTD.

注意事项

1. 为了保证无故障的高效工作，在设计系统期间应根据工况仔细选择液压系统的液压油，所有矿物油基液压油均在某种程度上适用于轴向柱塞元件，它们的应用时基本划分取决于上述的水、粘度与温度关系，并考虑氧化和腐蚀保护、材料相容性、空气和水分离特性。

2. 为了保证设备有长的使用寿命，必须进行良好而可靠的过滤。油液中的硬颗粒污染不得超过以下等级：

等级9——按 NAS1638

等级6——按 SAE

等级18 / 15——按 ISO / DIS 4406

在油液温度很高时，最低清洁度为：

等级8——按 NAS1638

等级5——按 SAE

等级17 / 14——按 ISO / DIS 4406

3. 为了正确选择液压油，必须知道与环境温度有关的工作温度；在闭式回路中这是回路温度，在开式回路中这是油箱温度。

4. 注意：漏油(壳体泄油)温度受压力和转速的影响，总是高于回路温度，然而要求回路中任何点温度不得超过90℃。

如果由于极端的工作参数或较高的环境温度，而不能维持上述条件，订货时请询问我公司。

5. 泵的进油口压力(绝对压力)处须 $\geq 0.08\text{MPa}$ ，及泄油压力(壳体内允许的最高压力)为 0.2MPa (绝对压力)，壳体内压力值必须等于或高于作用在轴密封上的外部压力值。

6. 安装位置：一般要求液压泵 / 马达安装位置、壳体上边缘低于油箱最低液面。若安装需在油面以上，请在订货时提出。

《样本》所述技术资料，仅供参考。若有特殊要求请与我集团公司技术部门咨询，若有更改，恕不通知。

The technical information in the catalog is for your reference. Please consult our technical Dept., if you have any special requirements.

NOTES

1. In order to guarantee trouble-free and efficient operation, the hydraulic fluid in a hydrostatic system should be selected carefully according to the actual working conditions during the design of the system. All mineral oil based fluids are suitable to a greater or lesser degree for application in axial piston units. Their basic classification of application results from what has already been said due to the water, viscosity and temperature relationships, with consideration of oxidization and corrosion protection, material compatibility, air and water separation characteristics.

2. In order to guarantee a long service life for the installation, good and reliable filtration is necessary. The hard particle contamination of fluid may not exceed a level determined by:

Class 9 to NAS 1638

Class 6 to SAE

Class 18/15 to ISO/DIS 4406

When the fluid temperature is too high, the required minimum degree of cleanliness is:

Class 8 to NAS 1638

Class 5 to SAE

Class 17/14 to ISO/DIS 4406

3. In order to select the correct fluid, it is necessary to know the operating temperature in the circuit in relation to the ambient temperature—in an open circuit and the tank temperature.

4. Important: The leakage oil(case drain oil)temperature is influenced by pressure and pump speed and is always higher than the circuit temperature. However, at no point in the circuit may the temperature exceed 90℃.

If it is not possible to comply with the above conditions because of extreme operating parameters or high ambient temperatures, please consult us.

5. The minimum pressure at the suction port of the pump $\geq 0.08\text{Mpa}$ (absolute pressure), and the drain pressure(max. permissible casing pressure)is 0.2MPa (absolute pressure). The pressure in the housing must be the same or greater than the external pressure on the shaft seal.

6. Installation position: in general, the upper point on the pump/motor housing must be below the minimum oil level of the tank. If you would like to install it above the minimum oil level, please indicate when order.

北京华德液压工业
集团有限责任公司
BEIJING HUADE HYDRAULIC
INDUSTRIAL GROUP CO., LTD.

A6V 变量马达 Variable Displacement Motor A6V

用于开式和闭式回路 斜轴式轴向柱塞结构
For open and closed circuits axial tapered piston, bent axis design

RC91100/12.2004

规格 Size 28-500

高压范围 Peak pressure 至 up to 35MPa

替代: Replace RC91100/09.2003



说明:

- 该变量马达是专为带次级控制的静液驱动设计的。
- 配有最大调节范围 $V_{max}/V_{min}=3.47$ 的整套控制总成。

Description

The variable displacement motor was designed especially for hydrostatic drives with secondary controls.
A complete control assembly for a maximum swivel range of $V_{max}/V_{min}=3.47$ is fitted.

特点:

- 用静液传动时有较大的调节范围
- 次级控制和带有各种控制装置的调节
- 在较小的倾角下提高最高输出转速
- 由于可用较小的泵而节省费用
- 省掉多速比齿轮驱动
- 高功率密度
- 允许高的外界轴载荷
- 任选安装位置
- 高效率
- 优秀的起动特性
- 小惯量

Special Characteristics

Large control range with hydrostatic transmissions.
Secondary control regulation with various control devices.
Increased maximum output speeds at reduces swivel angle.
Cost-saving due to the possibility of using smaller pumps
Obviates the multispeed ratio gear drives.
High power density.
Optional mounting position.
High efficient.
Excellent starting characteristics.
Low inertia.

剖视图:

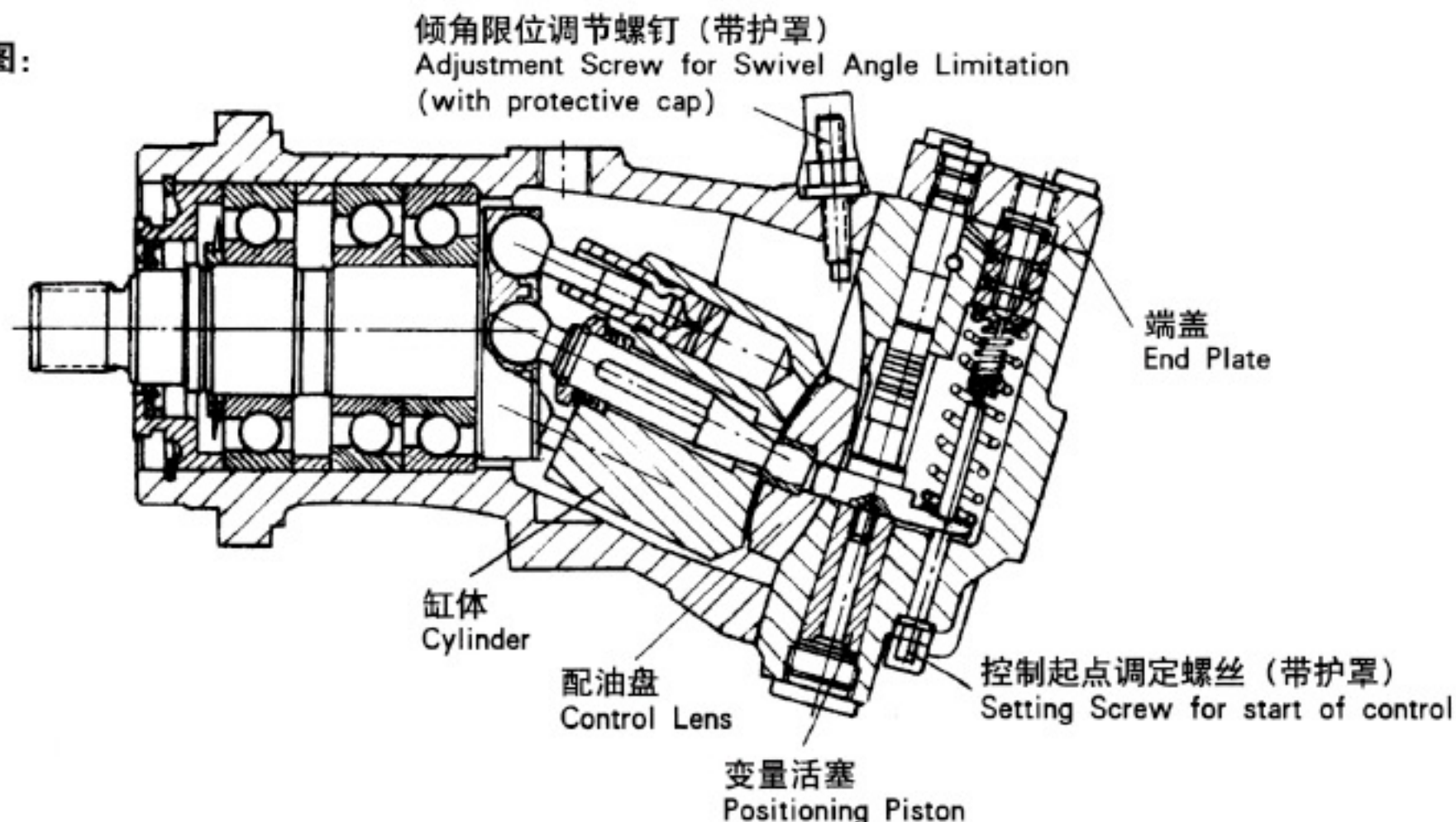

A6V 变量马达 Variable Displacement Motor A6V

型号 Type Code

A6V 80 HA2 2 F Z 2 - 039

马达型号 Motor Type

变量马达 Variable displacement motor

A6V

规格 Size

8.1-28.1ml/r

28

15.8-54.8ml/r

55

23-80ml/r

80

30.8-107ml/r

107

46-160ml/r

160

64.8-225ml/r

225

137-500ml/r

500

(排量 $V_{gmin}-V_{gmax}$) Displacement

变量方式 Control Device

液控变量 Hydraulic control, pilot pressure related	控制压差 $\Delta p=1\text{MPa}$ Pilot pressure increase 带恒压控制 $\Delta p=1\text{MPa}$ With pressusre control 控制压差 $\Delta p=2.5\text{MPa}$ Pilot pressure increase 带恒压控制 $\Delta p=1\text{MPa}$ With pressusre control	HD1 HD1D HD2 HD2D
---	--	----------------------------

液控双速变量 Hydraulic 2-speed control pilot pressure related	控制起点 Start of control 0.2-2MPa 控制起点 Start of control 0.5-5MPa	HS1 HS2
--	--	------------

高压自动变量 Automatic control, high pressure related	恒压 Constant pressure 不带超调 Without override 带超调 With override 升压 Pressure increase $\Delta p=10\text{MPa}$ 不带超调 Without override 带超调 With override	HA1 HA1H HA2 HA2H
--	---	----------------------------

转速液控变量	Hydraulic control, speed related	DA
--------	-------------------------------------	----

电控双速变量	Electrical 2-speed control 12V (with switching solenoid)24V	ES1 ES2
--------	--	------------

电控比例变量	Electrical control 12V (with proportional solenoid) 24V	EP1 EP2
--------	--	------------

扭矩变量 手动变量	Mooring control Manual control (with handwheel)	MO MA
--------------	---	----------

最小排量设定值

Min.Swept Volume Setting

例: Example.

$V_{gmin}=39\text{ml/r}$

039

起重机系列产品专用(带单向节流阀)

For crane products

-

装配型式 Assembly Type

解释见变量说 明及元件尺寸	For explanation see description of control device and unit dimensions	1 2
------------------	---	--------

轴伸 Shaft End

平键 GB 1096-79 花键 DIN 5480 花键 GB 3478.1-83	Keyed parallel shaft Splined shaft Splined shaft	P Z S
---	--	-------------

油口连接 Pipe Connections

SAE 法兰, 侧面 螺纹连接, 侧面	SAE flange, on side Metric threads, on side	F G
------------------------	--	--------

结构型式 Series

结构 2, 规格 28-225 结构 5, 规格 250-500	Series 2, sizes 28-225 Series 5, size 250-500	2 5
-------------------------------------	--	--------

订货示例: A6V80HD12FZ2 -039 Ordering Example A6V80HD12FZ2-039

斜轴变量马达 A6V, 规格 80, 液控变量, $\Delta p=1\text{MPa}$, 结构 2, 侧面 SAE 法兰连接, 德标花键, 第 2 种装配型式, 最小排量 $V_{gmin}=39\text{ml/r}$

Axial piston variable displacement motor A6V, size 80, with hydraulic control, pilot pressure related, $\Delta p=1\text{MPa}$, series 2. SAE flange connections on side, splined shaft, assembly type 2, min. swept volume setting $V_{gmin}=39\text{ml/r}$

A6V 变量马达 Variable Displacement Motor A6V

技术参数 Technical Data

工作压力范围: Operating Pressure Range

A或B口压力: Pressure at port A or B
 额定压力 Nominal pressure $P_n=31.5\text{MPa}$
 最高压力 Peak pressure $P_{max}=35\text{MPa}$
 A、B油口压力 The sum of the pressures at ports A and B should not exceed 63MPa.
 63MPa, 每侧油口 (Individual pressure at either port max.35MPa)
 压力最高35MPa.
 泄油压力: Leakage oil Pressure:
 允许T口最大 MaXimum permissible leakage oil pressure
 泄油压力 (at Port T)
 $P_{abs} \leq 0.2\text{MPa}$

油温范围: Fluid Temperature Range

$t_{min} \leq -25^\circ\text{C}$
 $t_{max} \leq +80^\circ\text{C}$

粘度范围: Viscosity Range:

$V_{min} \leq 10\text{mm}^2/\text{s}$
 $V_{max} \leq$ (短时)(for short periods) $1000\text{mm}^2/\text{s}$

最佳工作粘度: Optimum Operating Viscosity:

$V_{opt} \leq 16-36\text{mm}^2/\text{s}$

油液选择: Fluid Recommendation

工作温度 Operating Recommended
 推荐粘度等级 Viscosity grade temperature to DIN51519
 符合DIN51519 range ISO(VG)

30-40°C	VG22=22mm ² /s	at40°C
40-50°C	VG32=32mm ² /s	at40°C
50-60°C	VG46=46mm ² /s	at40°C
60-70°C	VG68=68mm ² /s	at40°C
70-80°C	VG100=100mm ² /s	at40°C

液压油的过滤:

推荐过滤精度为10μm。亦可使用25-40μm的, 但使用10μm的可以延长使用寿命(降低磨损)。

转速范围:

最低转速没有限制, 在要求十分均匀的转速时, n_{min} 不小于50r/min
 最高转速由来自泵的最大流量和变量马达的最小排量确定。最小排量则由一个调节螺钉限位, 所以变量马达不会超速运转。
 最高允许转速见技术参数表。

Filtration of Hvdraulic Fluid

Recommended filtration 10μm. Coarser filtration of 25 to 40μm is possible, however longer service life is achieved with filtration of 10μm. (reduced wear).

Speed Range

No limitation on minimum Speed n_{min} . Where very even speeds are required, n_{min} should not be less than 50r/min. The maximum flow from the pump and the minimum swept volume of the variable motor together determine the maximum output speed. The min swept volume is limited mechanically by means of an adjustment screw so that the max. permissible speeds(of the variable motor and the driven unit)cannot be exceeded. See date table for max.permissible speeds.

规格计算:

Calculation of size

流量 Swept Volume	$Q = \frac{V_g \cdot n}{1000 \cdot \eta_v}$	[L/min]
输出转速 Output Speed	$n = \frac{Q \cdot 1000 \cdot \eta_v}{V_g}$	[r/min]
输出扭矩 Output Torque	$M = \frac{V_g \cdot \Delta p \cdot \eta_{mh}}{2\pi}$ $\frac{1.59 V_g \cdot \Delta p \cdot \eta_{mh}}{10}$	[Nm]
或 or	$M = \frac{K_M \cdot \Delta p \cdot \eta_{mh}}{10}$	[Nm]
输出功率 Output Power	$P = \frac{M \cdot n}{9549}$ $= \frac{Q \cdot \Delta p}{60} \cdot \eta_t$	[KW]

V_g =最大排量(ml/r) max geometry displacement[ml/r]
 M =扭矩(Nm) torque[Nm]
 Δp =压差(MPa) differential pressure[MPa]
 n =转速(r/min) speed[r/min]
 η_v =容积效率 volumetric efficiency
 η_{mh} =机械效率 mechanical-hydraulic efficiency
 η_t =总效率 overall efficiency

技术参数 Technical Data

规格	Size		28	55	80	107	160	225	500	
变量方式	Control Device									
HD 液控变量	Hydraulic control pilot pressure related		•	•	•	•	•	•	•	
HD1D 液控恒压变量	Hydraulic control pilot pressure related			•	•	•	•			
HS 液控(双速)变量	Hydraulic control(two speed), pilot pressure related		•	•	•	•	•	•	•	
HA 高压自动变量	Automatic control,high pressure related		•	•	•	•	•	•		
DA 转速液控变量	Hydraulic control.speed related		•	•	•	•	•			
ES 电控(双速)变量	Electric control (two speed)		•	•	•	•	•			
EP 电控(比例)变量	Electric control (proportional)		•	•	•	•	•			
MO 扭矩变量	Mooring control		•	•	•	•	•	•		
MA 手动变量	Manual control									
排量	Displacement	V_{gmax}	ml/r	28.1	54.8	80	107	160	225	500
		V_{gmin}	ml/r	8.1	15.8	23	30.8	46	64.8	137
最大允许流量	Max. Permissible. Swept volome	Q_{gmax}	L/min	133	206	268	321	424	530	950
最高转速	Max. speeds (在 at Q_{max} 下)	n_{max} 在 at V_{gmax}	r/min	4750	3750	3350	3000	2650	2360	1900
		n_{max} 在 at $V_g < V_{gmax}$	r/min	6250	5000	4500	4000	3500	3100	2500
扭矩常数	Torque constants	M_x 在 at V_{gmax}	Nm/MPa	4.463	8.701	12.75	16.97	25.41	35.71	79.577
		M_x 在 at V_{gmin}	Nm/MPa	1.285	2.511	3.73	4.9	7.35	10.30	21.804
最大扭矩	Max. torque (在 at $\Delta p=35\text{MPa}$)	M_{max} 在 at V_{gmax}	Nm	156	304	446	594	889	1250	2782
		M_{max} 在 at V_{gmin}	Nm	45	88	130	171	257	360	763
最大输出功率(在 35MPa 和 Q_{max} 下)	Max.output power(at 35MPa and Q_{max})		kW	78	120	156	187	247	309	507
惯性矩	Moment		kgm ²	0.0017	0.0052	0.0109	0.0167	0.0322	0.0532	
重量	Weight		kg	18	27	39	52	74	103	223

A6V 变量马达 Variable Displacement Motor A6V

HD液控变量

按外控油源的先导压力来无极的控制马达的排量

标准结构：按第2种装配型式供货

控制起点在 V_{gmax} (最大扭矩、最低转速)

控制终点在 V_{gmin} (最小扭矩、最高转速)

对于第一种装配型式，控制功能相反：

控制起点在 V_{gmin} 控制终点在 V_{gmax} 。

变量机构的设定

有两种方案供选用：

1. HD1-先导压力压差(由 $V_{gmax} \rightarrow V_{gmin}$) - $\Delta Ps=1MPa$

控制起点可调从0.2-2MPa

标准设定值：控制起点压力为0.3MPa，控制终点压力1.3MPa

2. HD2-先导压力压差(由 $V_{gmax} \rightarrow V_{gmin}$) - $\Delta Ps=2.5MPa$

控制起点可调 从0.5-5MPa

标准设定值：控制起点压力为1MPa，控制终点压力为3.5MPa，当用

HD作双速控制时，最高先导压力可到7.5MPa

外控口x处的供油量：约0.5L/min.

当工作压力 $<1.5MPa$ 时，必须在G口供人1.5MPa的辅助压力。

Hvdraulic Control Pilot Pressure Related,HD

Stepless control of the motor capacity dependent on a pilot pressure signal.

Standard model:assembly type 2

Start of control at V_{gmax} (max.torque, min.speed)

End of control at V_{gmin} (min.torque, max.speed)

For assembly type 1, the control function is reversed:

Start of control at V_{gmin} , end of control at V_{gmax}

Setting of Regulator

Two options are available:

1. HD1

Pilot pressure increase adjustable($V_{gmax}-V_{gmin}$)- $\Delta Ps=1MPa$

Start of control adjustable-from 0.2-2MPa

Standard setting: start of control at 0.3MPa(end of control at 1.3MPa)

2. HD2

Pilot pressure increase($V_{gmax}-V_{gmin}$)- $\Delta Ps=2.5MPa$

Start of control adjustable-from 0.5-5MPa

Standard setting:start of control at 1.0MPa(end of control at 3.5MPa)

When using the HD control as a two-point control a max.pilot pressure of 7.5MPa is permissible.

The max oil flow at pilot X is approx 0.5L/min.

Should the available operating pressure be $<1.5MPa$ then an auxiliary pressure of 1.5MPa must be applied at port G.

HD. 液控变量(HD1, HD2)

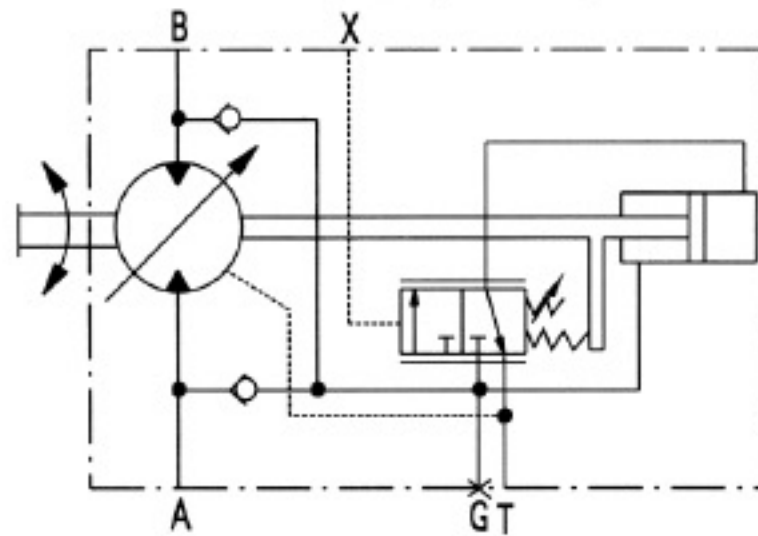

HD1D液控恒压变量

恒压控制是在HD功能基础上增加的。

如果系统压力由于负载扭矩缘故或由于马达摆角减小而升高，则达到恒压控制的设定值时，马达摆出到较大的摆角。

由于增大排量和减小压力，控制偏差消失。

通过增大排量，马达在恒压下产生较大扭矩。

恒压控制阀的设定范围为8-35MPa.

标准型：按第二种装配型式供货。

控制起点在 V_{gmax} (最大扭矩、最低转速)

控制终点在 V_{gmin} (最小扭矩、最高转速)

HD1D:Constant pressure control

The constant pressure control is superimposed on the HD function.

Should system pspressure rise as a result of the load torque or reduction of the motor swivel angle, When the setting swivelled out to a higher angle.

As a result of the increased displacement and consequent pressure reduction, the control debiation is eliminated. By increaseneing the displacement the motor produces a higher torque at a constant pressure.

Setting range of constant pressure control valve: 8-35MPA

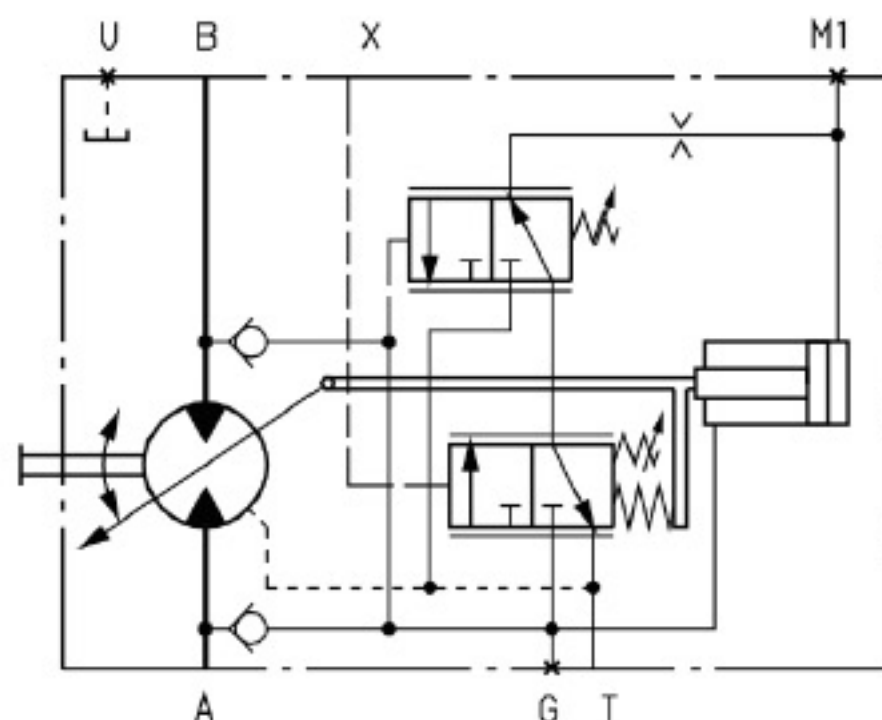

HS液控双速变量

按外控油源的先导压力来两点式的控制马达排量
标准结构：按第2种装配型式供货。

控制起点在 V_{gmax} (最大扭矩、最低转速)

控制终点在 V_{gmin} (最小扭矩、最高转速)

对于第一种装配型式，控制功能相反：

控制起点在 V_{gmin} 控制终点在 V_{gmax} 。

变量机构的设定

有两种方案供选用

1. HS1—控制起点可调—从0.2—2MPa
2. HS2—控制起点可调—从0.5—5MPa

(由 $V_{gmin} \rightarrow V_{gmax}$)— $\Delta p \leq 0.2MPa$

外控口x处的供油量：约0.5L/min.

当工作压力 $< 1.5MPa$ 时，必须在G口供入1.5MPa的辅助压力。

Hydraulic Control, 2-Speed Pilot Pressure Related, HS

Two point Control of the motor capacity dependent on a pilot pressure signal.

Standard model: assembly type 2

Start of control at V_{gmax} (max.torque, min speed)

End of control at V_{gmin} (min.torque, max, speed)

For assembly type 1, the control function is reversed:

start of control at V_{gmin} , end of control at V_{gmax} .

Setting of Regulator

Two options are available:

1. HS1—Start of control adjustable—from 0.2—2MPa
2. HS2—Start of control adjustable—from 0.5—5MPa

($V_{gmin} - V_{gmax}$)— $\Delta P \leq 0.2MPa$

The max oil flow at pilot X is approx 0.5L/min.

Should the available operating pressure be $< 1.5MPa$ then an auxiliary pressure of 1.5MPa must be applied at port G.

HS. 液控双速变量(HS1, HS2)

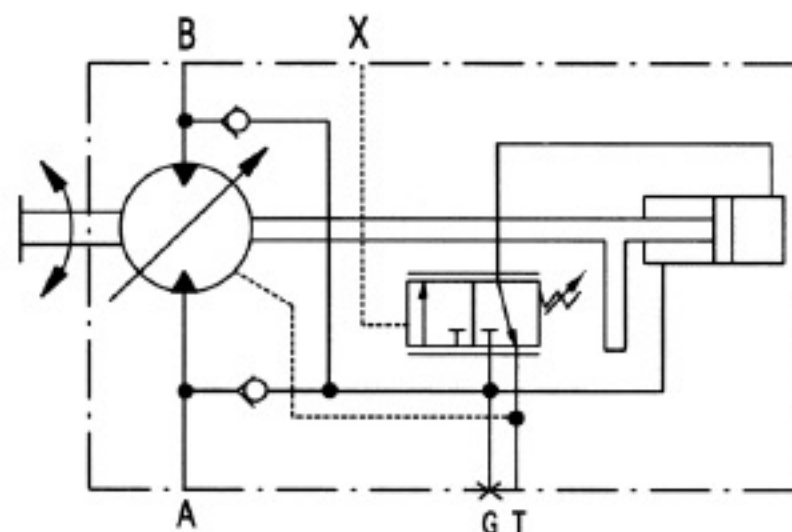

HA高压自动变量

按工作压力自动控制马达排量

标准结构：按第1种装配型式供货

控制起点在 V_{gmin} (最小扭矩、最高转速)

控制终点在 V_{gmax} (最大扭矩、最低转速)

此种变量方式，当A或B口的内部工作压力达到设定值时，
马达由最小排量 V_{gmin} 向最大排量 V_{gmax} 转变。

控制起点在8至35MPa间可调，

有两种方式供选用：

1. HA1—在工作范围内，工作压力保持恒定。 $\Delta P=1MPa$
从 V_{gmin} 变至 V_{gmax} 时，压力升高约为1MPa。
2. HA2—在工作范围内，工作压力升高。 $\Delta P=10MPa$
从 $V_{gmin}(7^\circ C)$ 变至 $V_{gmax}(25^\circ C)$ 时，压力升高10MPa。

HA变量可在X口进行外控(即带有超调)，在这种情况下，变量机构的压力设定值(工作压力)按每0.1MPa先导(外控)压力下降1.6MPa的比率降低。

例如：

变量机构起始变量压力设定值为30MPa。

先导压力(X口)：0MPa时变量起点在30MPa。

先导压力(X口)：1MPa时变量起点变为14MPa。

($30MPa - 10 \times 1.6MPa = 14MPa$)

Automatic Control, High Pressure Related, HA

Automatic control of motor capacity dependent on operating pressure.

Assembly type 1 Standard model: assembly type 1

Start of control at V_{gmin} (min.torque, max speed)

End of control at V_{gmax} (max.torque, min speed)

This control device measures the internal operating pressure at port A or B (no pilot line required), and when the set operating pressure is reached, swivels the motor from min. capacity(V_{gmin})to max.capacity(V_{gmax}).

Start of control is adjustable between 8MPa and 35MPa.

Two options are available:

1. HA1—Within the control range, the operating pressure is held practically constant. $\Delta P=1MPa$ Pressure increase between V_{gmin} and V_{gmax} is approx 1MPa.
2. HA2—Within the control range, with pressure increase $\Delta P=10MPa$ from $V_{gmin}(7^\circ C)$ to $V_{gmax}(25^\circ C)$.

The HA control can be overridden at port X. In this case, the set value of pressure at the regulator (operating pressure) is reduced 1.6MPa per 0.1MPa pilot pressure.

Example:

Regulator setting: 30MPa.

Pilot pressure(at X): 0MPa start of control at 30MPa

Pilot pressure(at X): 1MPa start of control at 14MPa

($30MPa - 10 \times 1.6MPa = 14MPa$)

A6V 变量马达 Variable Displacement Motor A6V

带有超调的HA，变量有两种方式供选用：

1. HA1H-在控制范围内，工作压力保持恒定， $\Delta P=1\text{MPa}$ 。
 2. HA2H-在控制范围内，工作压力升高， $\Delta P=10\text{MPa}$ 。
- 如果控制仅需达到最大排量，则允许先导压力最高为 5MPa 。
外控口X处的供油量 0.5L/min 。

Two options are available for HA control with override.

1. HA1H-With in the control range, the operating pressure is held, practically constant, $\Delta P=1\text{MPa}$.
 2. HA2H-With in the control range, the operating pressure in crease, $\Delta P=10\text{MPa}$.
- If override is only required to set max.capacity(swivelling the motor to V_{gmax}), a pilot pressure of up to 5MPa max is permissible.
The max oil flow at X is approx 0.5L/min .

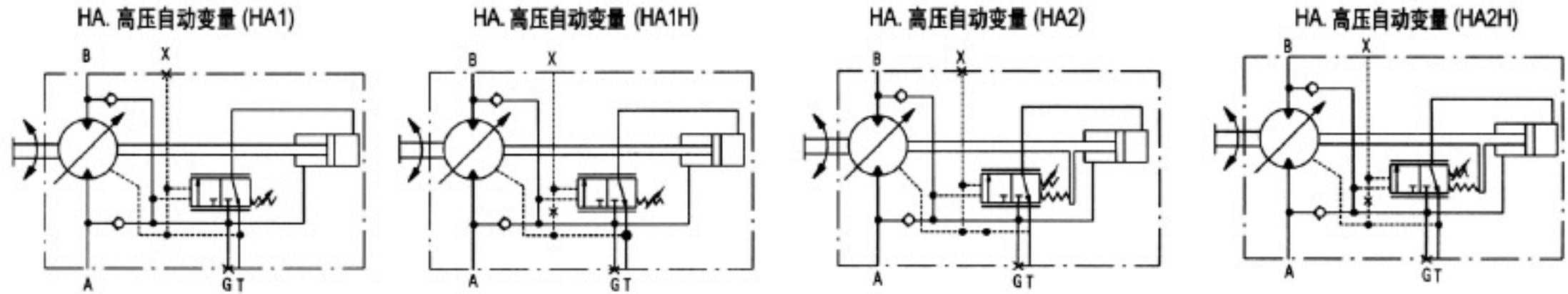

ES, 电控双速变量

达排量处于 V_{gmin} 或 V_{gmax} 是由控制电磁铁通断来实现。
标准结构：按第2种装配型式供货
控制起点在 V_{gmax} (最大扭矩、最低转速)
控制终点在 V_{gmin} (最小扭矩、最高转速)
对于第一种装配型式，控制功能相反：
有四种方案供选用：
ES1-控制电压 12VDC （电磁铁为法兰连接）
ES2-控制电压 24VDC （电磁铁为法兰连接）
ES3-控制电压 12VDC （电磁铁为螺纹连接）
ES4-控制电压 24VDC （电磁铁为螺纹连接）

ES, Electrical 2-Speed Control

The motor capacity is set to V_{gmin} or V_{gmax} by switching on or off an electrical current at the switching solenoid.
Standard model: assembly type 2
Start of control at V_{gmax} (max.torque min speed)
End of control at V_{gmin} (min.torque max speed)
For assembly type 1 the control function is reversed.
Two options are available:
ES1-control voltage 12VDC (solenoid connected by bolts)
ES2-control voltage 24VDC (solenoid connected by bolts)
ES3-control voltage 12VDC (solenoid connected by threads)
ES4-control voltage 24VDC (solenoid connected by threads)

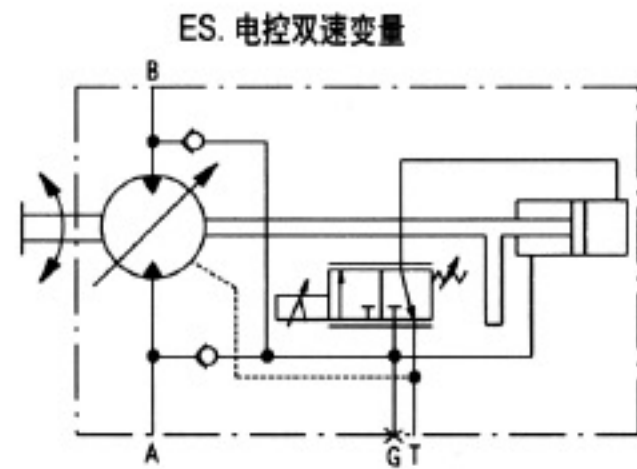

EP, 电控比例变量

根据电信号无级的或双点的控制马达排量
标准结构：按第2种装配型式供货
控制起点在 V_{gmax} (最大扭矩、最低转速)
控制终点在 V_{gmin} (最小扭矩、最高转速)
对于第一种装配型式，控制功能相反：
能过比例电磁铁操纵液压控制。
有两种方案供选用：
1. EP1-控制电压 12VDC $400\text{mA}-900\text{mA}$
2. EP2-控制电压 24VDC $200\text{mA}-450\text{mA}$
如果仅要求变量马达作双点(双速)控制，则只要使电流通断即可得到这两个位置(对第2种装配型式在 V_{gmax} 断电，对第1种装配型式在 V_{gmin} 断电)。
如果工作压力低于 1.5MPa ，则在G口要求引入 1.5MPa 的辅助压力。

EP Electrical Proportional Control

For two-speed control of the motor capacity, or for two point control dependent on an electrical signal.
Standard model: assembly type 2
Start of control at V_{gmax} (max.torque, min.speed)
End of control at V_{gmin} (min.torque, max.speed)
For assembly type 1, the control function is reversed.
The hydraulic control is operated by a proportional solenoid.
Two options are available:
1. EP1-control voltage 12VDC
2. EP2-control voltage 24VDC
Should the variable motor only be required for two point control, simply switching the current on and off is sufficient to attain these two positions(for assembly type 2:deenergise at V_{gmax} , for assembly type 1:deenergise at V_{gmin} . if the operating pressure is less than 15MPa , then an auxiliary pressure of 15MPa is required at port G.

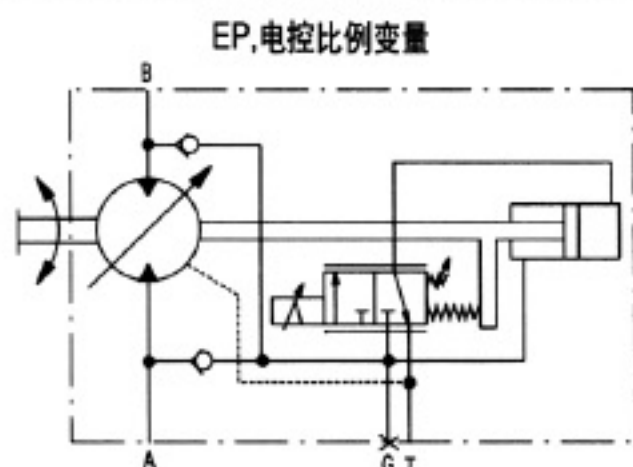

A6V 变量马达 Variable Displacement Motor A6V

DA.转速液控变量

转速液控变量只用于与变量泵A4V.DA合用的传动系统。

装配型：2

变量起点，按先导压力：在 V_{gmax} (到 V_{gmin})

按工作压力：在 V_{gmin} (到 V_{gmax})

起点在 V_{gmax} (最大扭矩)。

由A4V变量泵确定的先导压力(提高原动机转速=提高变量泵转速=提高先导压力)引到X1或X2口，视行驶方向而定，使马达向减小排量方向转变(扭矩减小，转速增加)。

若工作压力升高到超过变量机构设定的压力值，则马达向增大排量方向转变(扭矩增大，转速降低)。

先导压力与高压保持定值： $P_{st}/PH=3/100$ 。

先导压力变化0.3MPa(升或降)相应使工作压力升、降10MP。

设计带DA变量的驱动时，必须考虑A4V.DA变量泵的技术数据。

DA. 转速液控变量

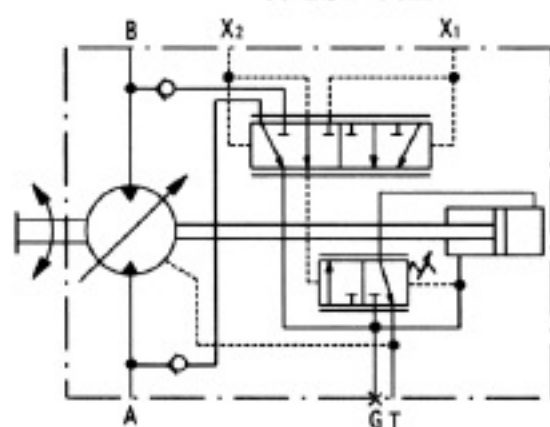

DA Hydraulic Control.Speed Related.

Speed related hydraulic control is used exclusively for transmission drives in conjunction with variable pump A4V.DA.

Assembly design 2

Start of control, pilot pressure dependent at V_{gmax} (to V_{gmin}), high pressure dependent at V_{gmin} (to V_{gmax}).

Start point at V_{gmax} (max.torque).

The pilot pressure, which is determined by the variable pump A4V (increasing speed of prime mover=increasing speed of variable pump=increasing pilot pressure)is directed to ports X1 or X2 dependent on the direction of travel, and causes a swivelling towards smaller motor capacity(lower torque, higher speed).

Should the operating pressure rise above the set pressure value at the regulator, the variable motor swivels to a higher capacity(higher torque, lower speed).

Pilot pressure and high pressure remain in a fixed relationship $P_{st}/PH=3/100$.

0.3MPa variation pilot pressure(rise or fall)gives a pressure rise or fall of 10MPa in operating pressure.

When designing a drive with a DA control the technical data of the variable pump type A4V.DA must be considered.

MO.扭矩变量

扭矩变量，主要用来驱动绞车，产生恒定的牵引力。

装配型式：第1种装配型式

控制起点在 V_{gmin} (最小扭矩、最高转速)

变量机构的设定：

先导压力升高 $(V_{gmin}-V_{gmax})\Delta p=5MPa$ ，控制起点从8-35MPa，可调(订货时注明)。

通过改变马达的排量可以得到恒定的扭矩，它可根据需要进行改变，使绞车产生恒定的牵引力。如果卷筒上没有拉力，则马达在较低的压力下工作，从而先导压力也较低，马达排量减小，转速增加，绞车加速运转，直至达到绞车的拉力时保持拉力并停止运转。为限制马达的最高转速，在回中马达前面应设有流量阀或尖似元件。

作为扭矩变量本身的先导控制，可采用一个溢流阀调节。X口最大供油量约为5L/min，随先导压力与工作压力差的降低，先导油液流量也减小。

MO.扭矩变量

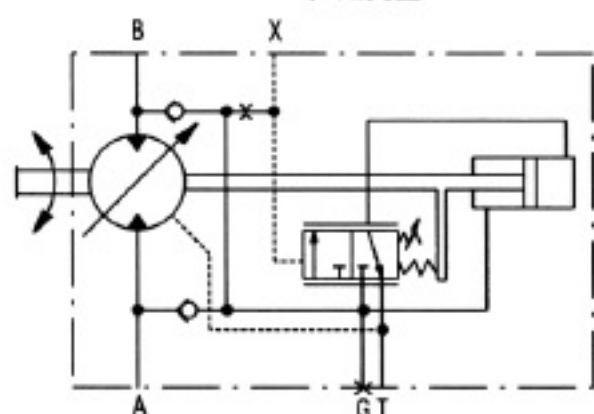

MO.Mooring Control

The mooring control is used mainly for the drive of winches, to generate a constant line pull.

Assembly type 1

Start of control at V_{gmin} (min.torque, max.speed)

Setting of Regulator

Pilot pressure increase $(V_{gmin}-V_{gmax})\Delta p=5MPa$.

Start of control adjustable from 8 to 35MPa(must be indicated in cleat text when ordering).

A constant torque, which may be altered according to requirements in order to generate a constant line pull at the winch is achieved by varying the capacity of the variable motor.If there is no pull at the drum, the variable motor requires a lower operating pressure and therefore generates a smarter pilot pressure. The variable motor moves to a min.capacity(V_{gmin}). The higher motor speed thus resulting(warping speed)causes rapid operation of the winch until the mooring pull required of the winch is reached and set. In order to limit the maximum speed of the variable motor, a flow limiting valve, or other such suitable, must be placed in the circuit before the motor.

As a pilot control for the mooring control itself, a variable pressure relief valve may be used.The max.oil flow at port X is approx5L/min. The pilot oil flow reduces With lower differential pressure between pilot pressure and operating pressure.

MA手动变量

通过手轮驱动螺杆以调节马达的排量。装配型式：第1种装配型式

MA.手动变量

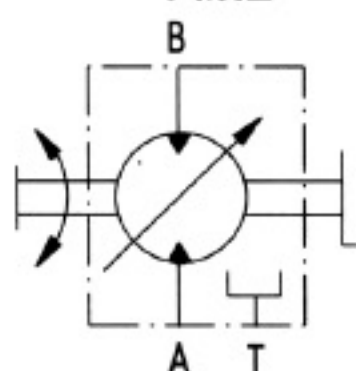

MA,Manual Control

Adjustment of motor capacity dependent on the position of a threaded spindle-hand operation. Assembly design 1

A6V 变量马达 Variable Displacement Motor A6V

通用特性曲线 General Operating Curve

(P-M) 和 $(V_g \frac{n}{n \text{ at } V_{gmax}})$ 特性
 Characteristic (P-M) and $(V_g \frac{n}{n \text{ at } V_{gmax}})$

扭矩 M(Nm)未计效率!
 Torque M(Nm)
 Without considering efficiencies!

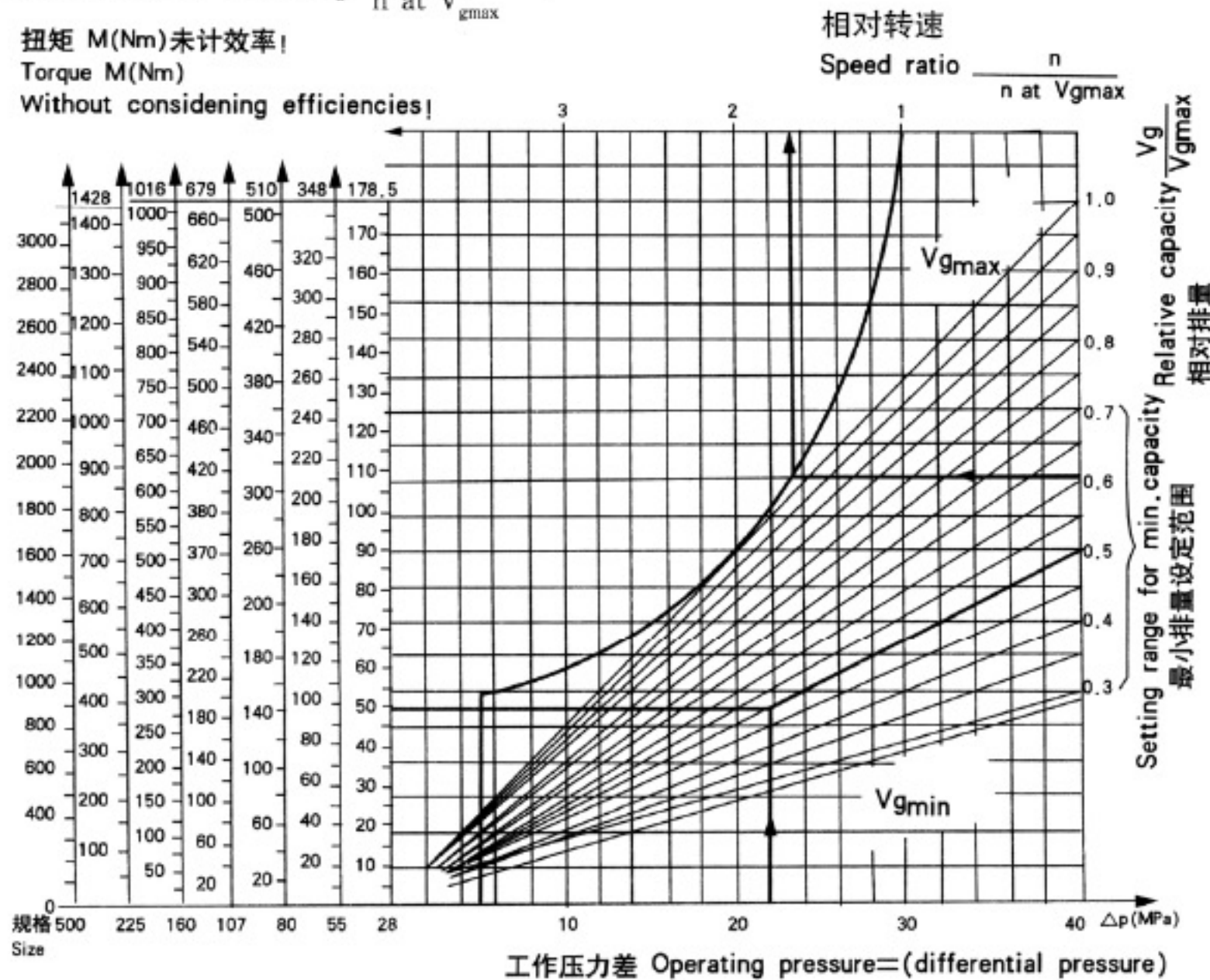

应用示例 1

规格 55; 压差 $\Delta P=22\text{MPa}$

排量 $V_g=27.4\text{ml/r}$

求: 输出扭矩 M

解: 相对排量

$$\frac{V_g}{V_{gmax}} = \frac{27.4}{54.8} = 0.5$$

在图表即可按 $V_g=0.5V_{gmax}$, $\Delta P=22\text{MPa}$ 查出 $M=96\text{Nm}$.

Example 1

Size 55

Differential pressure $\Delta P=22\text{MPa}$

Capacity $V_g=27.4\text{ml/r}$

Required: Output torque M

Solution: Capacity $V_g=27.4\text{ml/r}$

$$\frac{V_g}{V_{gmax}} = \frac{27.4}{54.8} = 0.5$$

$0.5V_{gmax}$ at 22 MPa gives an output torque M of 96Nm.

应用示例 2

规格 55 排量 $V_g=32.9\text{ml/r}$

求: 相对转速

$$\frac{V_g}{V_{gmax}} = \frac{32.9}{54.8} = 0.6$$

据此由图表中查出相对转速:

$$\frac{n}{n_{max}} = 1.666$$

即可同样流量下, 马达转速是最大排量 (V_{gmax}) 时的 1.666 倍。

Example 2

Size 55

Capacity $V_g=32.9\text{ml/r}$

Required: Speed ratio

Solution: Capacity $V_g=32.9\text{ml/r}$

$$\frac{V_g}{V_{gmax}} = \frac{32.9}{54.8} = 0.6$$

$0.6V_{gmax}$ gives a speed ratio of

$$\frac{n}{n_{max}} = 1.666$$

i.e. at the same flow, the variable motor speed of rotation at factor of 1.666 times the speed at max capacity (V_{gmax}).

转速与排量的极限值

Limiting values for speed and capacity

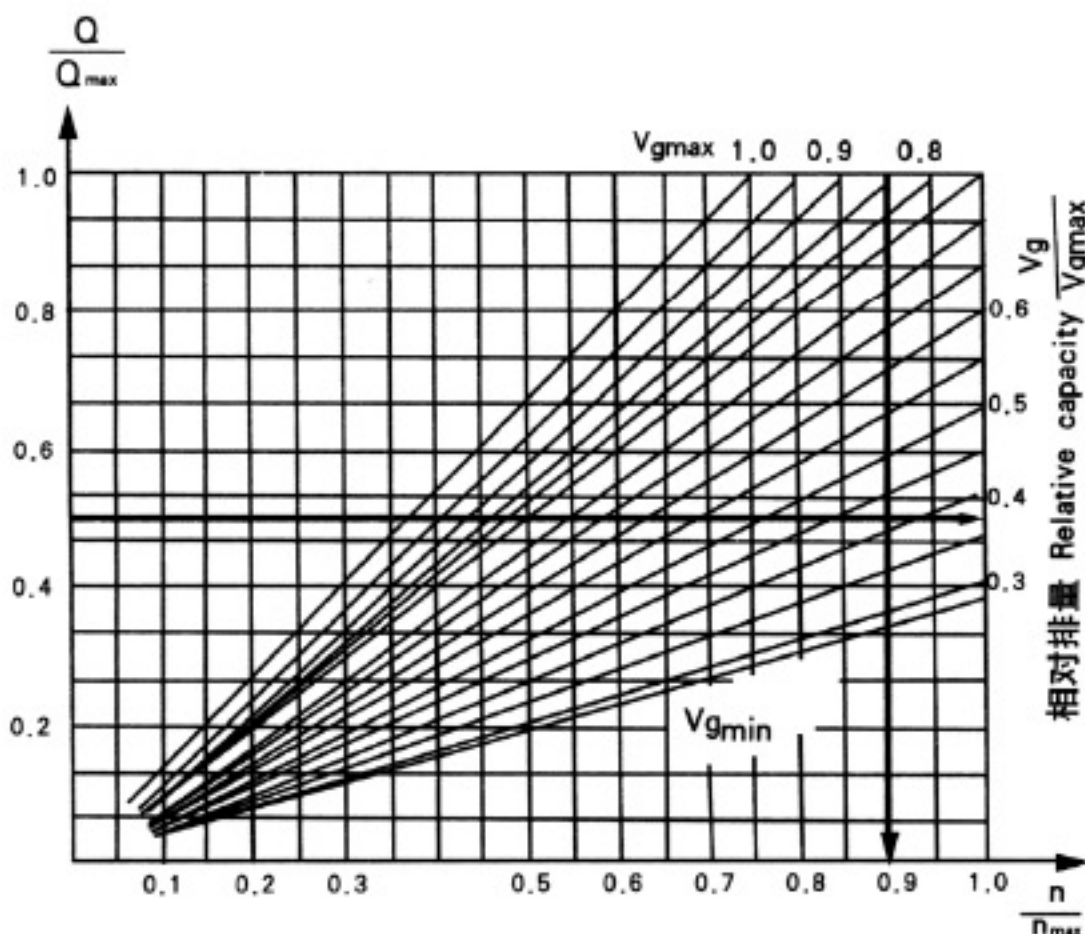

应用示例 1

规格 107

流量 $Q=160.5\text{L/min}$

求: 不超过马达允许最高转速的最小排量 (当 $V_g < V_{gmax}$)

解: 规格 107 的允许最大流量是:

$Q_{max}=321\text{L/min}$. 因此

$$\frac{Q}{Q_{max}} = \frac{160.5}{321} = 0.5$$

由表查出相对排量为:

$$\frac{V_g}{V_{gmax}} = 0.375$$

因此马达最小排量为:

$$0.375 \times V_{gmax} = 0.375 \times 107 = 40.125\text{ml/r}$$

应用示例 2

规格 107

马达排量 $V_g=91\text{ml/r} < V_{gmax}$

求: 允许最高转速 n

解:

相对排量

$$\frac{V_g}{V_{gmax}} = \frac{91}{107} = 0.85$$

据此在图表中查出对应的相对转速:

$$\frac{n}{n_{max}} = 0.9$$

$$\frac{n}{n_{max}}$$

$$\therefore n = 0.9n_{max}$$

$$= 0.9 \times 4000 = 3600\text{r/min}$$

Example 1

Size 107

Oil flow $Q=160.5\text{L/min}$

Required: Minimum permissible capacity in order not to exceed the maximum permissible motor speed (at $V_g < V_{gmax}$)

Solution: Max permissible oil flow for size 107 is 321L/min, therefore

$$\frac{Q}{Q_{max}} = \frac{160.5}{321} = 0.5$$

This gives a capacity of:

$$\frac{V_g}{V_{gmax}} = 0.375$$

The minimum motor capacity is therefore

$$0.375 \times V_{gmax} = 0.375 \times 107 = 40.125\text{ml/r}$$

Example 2

Size 107

Motor capacity $V_g=91\text{ml/r} < V_{gmax}$

Required:

Maximum permissible speed n

Solution: Motor capacity

$$V_g=91\text{ml} \quad \therefore \frac{V_g}{V_{gmax}} = \frac{91}{107} = 0.85$$

The motor capacity $0.85V_{gmax}$ gives

$$\frac{n}{n_{max}} = 0.9$$

$$\frac{n}{n_{max}}$$

$$n = 0.9 \times n_{max} = 0.9 \times 4000$$

$$= 3600\text{r/min}$$

A6V 变量马达 Variable Displacement Motor A6V

HD 特性曲线 Control curve

(P-M)和 $(V_g - \frac{n}{n \text{ at } V_{gmax}})$ 特性

Characteristic (P-M) and $(V_g - \frac{n}{n \text{ at } V_{gmax}})$
 扭矩 Torque M(Nm)

未计效率! Without considering efficiency!

相对转速

$$\text{Speed ratio } \frac{n}{n \text{ at } V_{gmax}}$$

控制起点在 0.5 和 5MPa 间可调 (设计 $\Delta P_s=2.5\text{MPa}$)

Beginning of control adjustable between 0.5 and 5MPa
 (design $\Delta P_s=2.5\text{MPa}$)

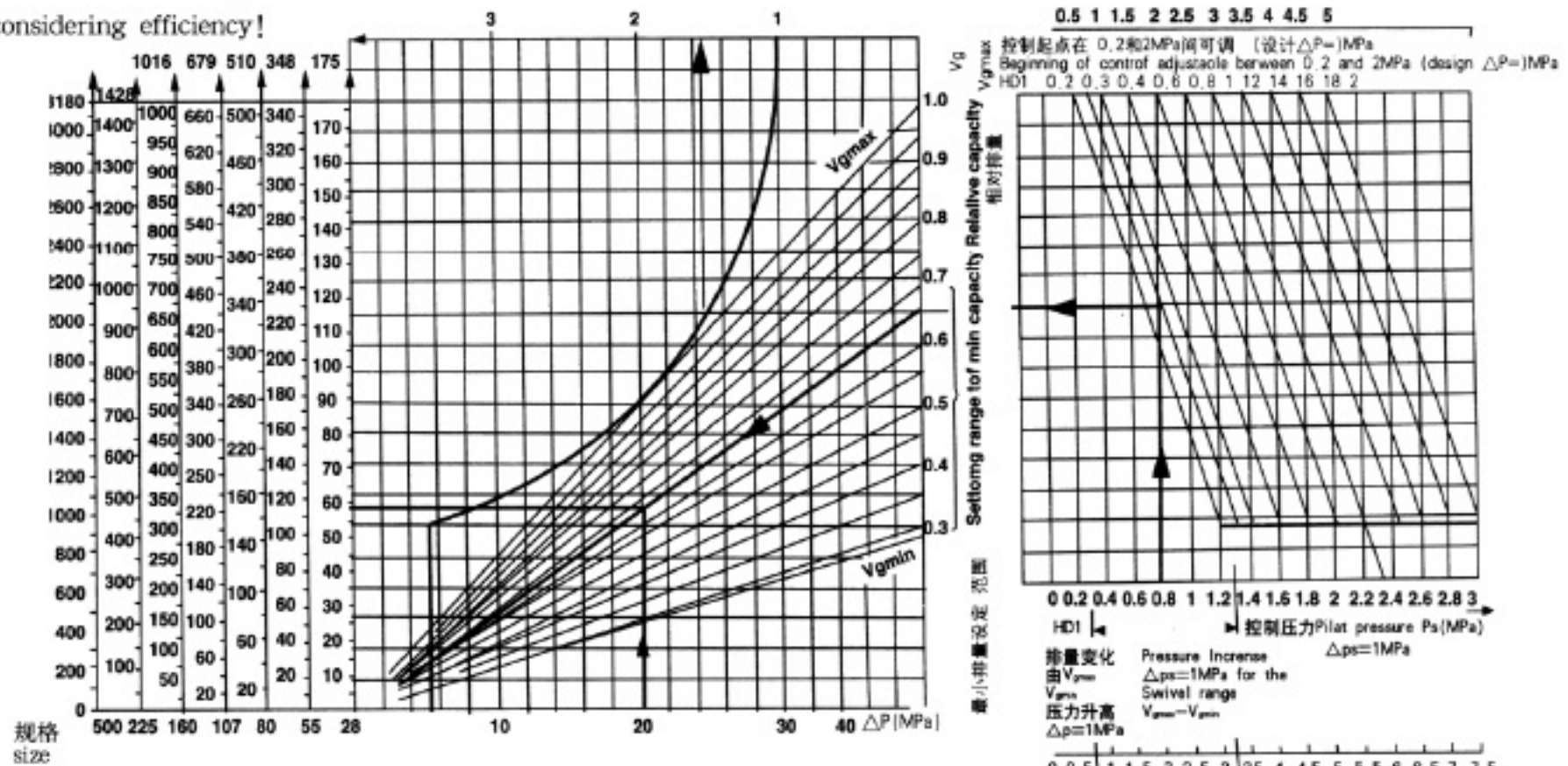

应用示例:

规格 55; HD1; $\Delta P_s=1\text{MPa}$

当 $P_s=0.8\text{MPa}$ 及 $\Delta P=20\text{MPa}$ 时

求: 输出扭矩和相对转速

解:

$$P_s=0.8\text{MPa 对应的 } \frac{V_x}{V_{gmax}} = 0.65$$

$$\text{和 } \frac{n}{n \text{ at } V_{gmax}} = 1.54$$

$$V_g=0.65 \times V_{gmax}=0.65 \times 54.8$$

$$=35.6\text{ml/r}$$

在 $\Delta P=20\text{MPa}$ 时的扭矩

$$M=114\text{Nm.}$$

Example

size 55; HD1

Start of control at pilot pressure increase

$\Delta P_s=1\text{MPa}$

available pilot pressure main pressure

$P_s=0.8\text{MPa}$ and $\Delta P=20\text{MPa}$

Required; Output torque and speed ratio

Solution; At a Pilot pressure of 0.8 MPa

$$\text{a capacity ratio } \frac{V_x}{V_{gmax}} = 0.65$$

$$\text{and speed ratio } \frac{n}{n \text{ at } V_{gmax}} = 1.54$$

$$\frac{V_g}{V_{gmax}} = 0.65 \text{ gives a capacity of}$$

$$0.65V_{gmax}=0.65 \times 54.8=35.6\text{ml/r}$$

At a main pressure (differential pressure)

of $\Delta P=20\text{MPa}$ the output torque will be

approximate approx 114Nm

EP 特性曲线 Control Curve

(P-M)和 $(V_g - \frac{n}{n \text{ at } V_{gmax}})$ 特性

Characteristic (P-M) and $(V_g - \frac{n}{n \text{ at } V_{gmax}})$

扭矩 Torque M(Nm)

未计效率! Without considering efficiency!

相对转速

$$\text{Speed ratio } \frac{n}{n \text{ at } V_{gmax}}$$

应用示例:

规格 55; 控制电流 385mA(24V)

工作压力 $\Delta P=20\text{MPa}$

求: 输出扭矩和相对转速

解: 查表得 385mA 时的相对排量

$$\frac{V_g}{V_{gmax}} = 0.6$$

其对应的转速比

$$\frac{n}{n \text{ at } V_{gmax}} = 1.666$$

即在相同的流量下, 马达转速是最大

排量 V_{gmax} 时的 1.666 倍。

由表中可以查出相对排量

$$\frac{V_g}{V_{gmax}} = 0.6$$

$$\text{则 } V_g=0.6V_{gmax}$$

$$=0.6 \times 54.8$$

$$=32.9\text{ml/r}$$

在 $\Delta P=20\text{MPa}$ 时的输出扭矩

$$M=105\text{Nm}$$

Example;

Size 55

Pilot current 385 mA(24V)

Operating pressure $\Delta P=20\text{MPa}$

Required; Output torque and speed ratio

Solution; At a pilot current of 385 mA,

a capacity ratio $\frac{V_g}{V_{gmax}} = 0.6$ and a speed ratio of

$$\frac{n}{n \text{ at } V_{gmax}} = 1.666$$

is obtained i.e. for same oil flow the variable motor

rotates at a factor of 1.666 faster than at max capacity

V_{gmax} . The capacity

$$\text{ratio } \frac{V_g}{V_{gmax}} = 0.6$$

gives a capacity of $0.6V_{gmax}=0.6 \times 54.8=32.9\text{ml/r}$. At

an operating pressure of $\Delta P=20\text{MPa}$ the output torque

is approx 105Nm.

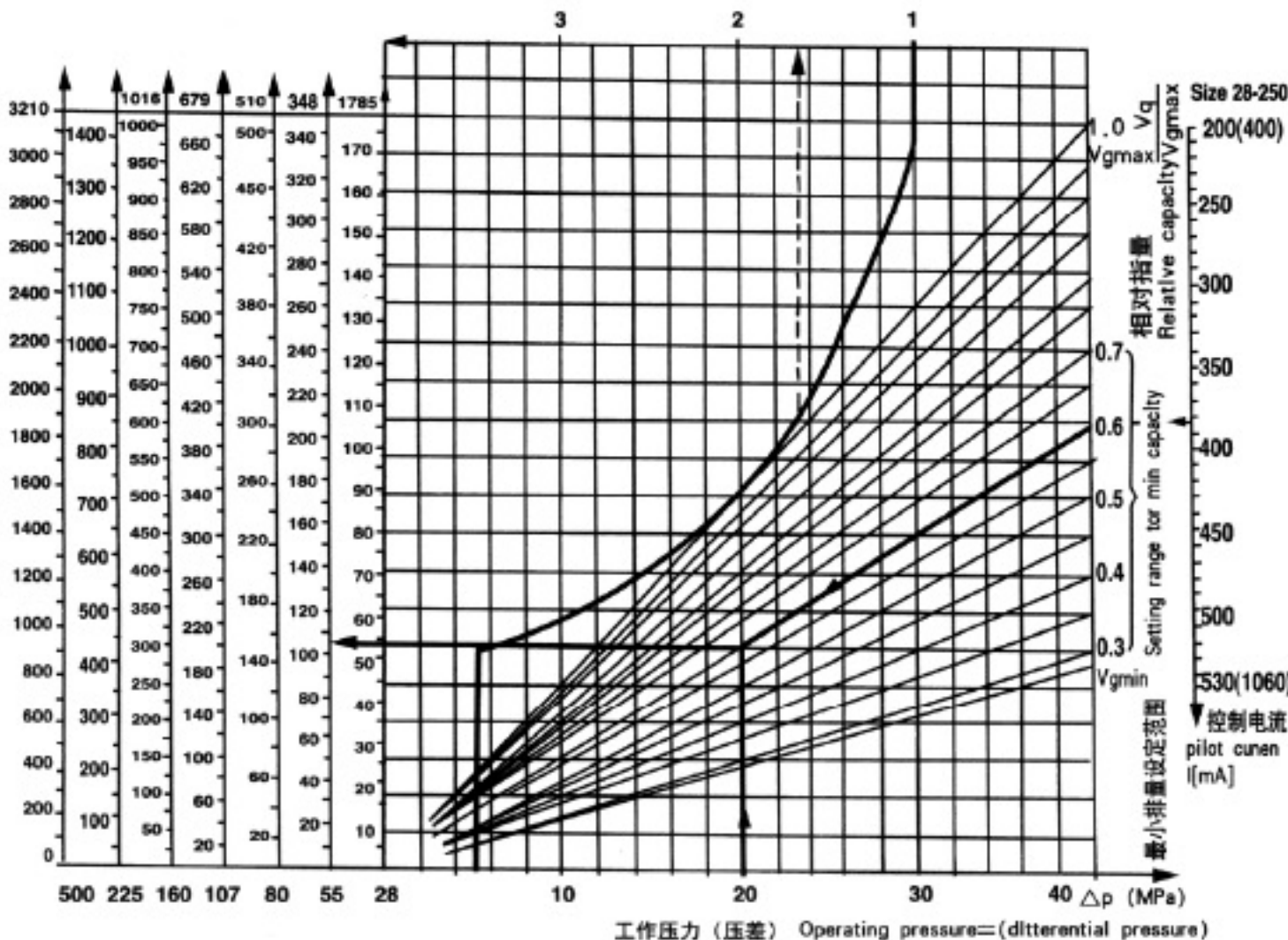

工作压力 (压差) Operating pressure=(differential pressure)

A6V 变量马达 Variable Displacement Motor A6V

HA 特性曲线 Control Curve

(P-M) 和 $(V_g - \frac{n}{n \text{ at } V_{gmax}})$ 特性

Characteristic (P-M) and $(V_g - \frac{n}{n \text{ at } V_{gmax}})$

相对转速

$$\text{Speed ratio } \frac{n}{n \text{ at } V_{gmax}}$$

扭矩 Torque M(Nm)

未计效率! Without considering efficiency!

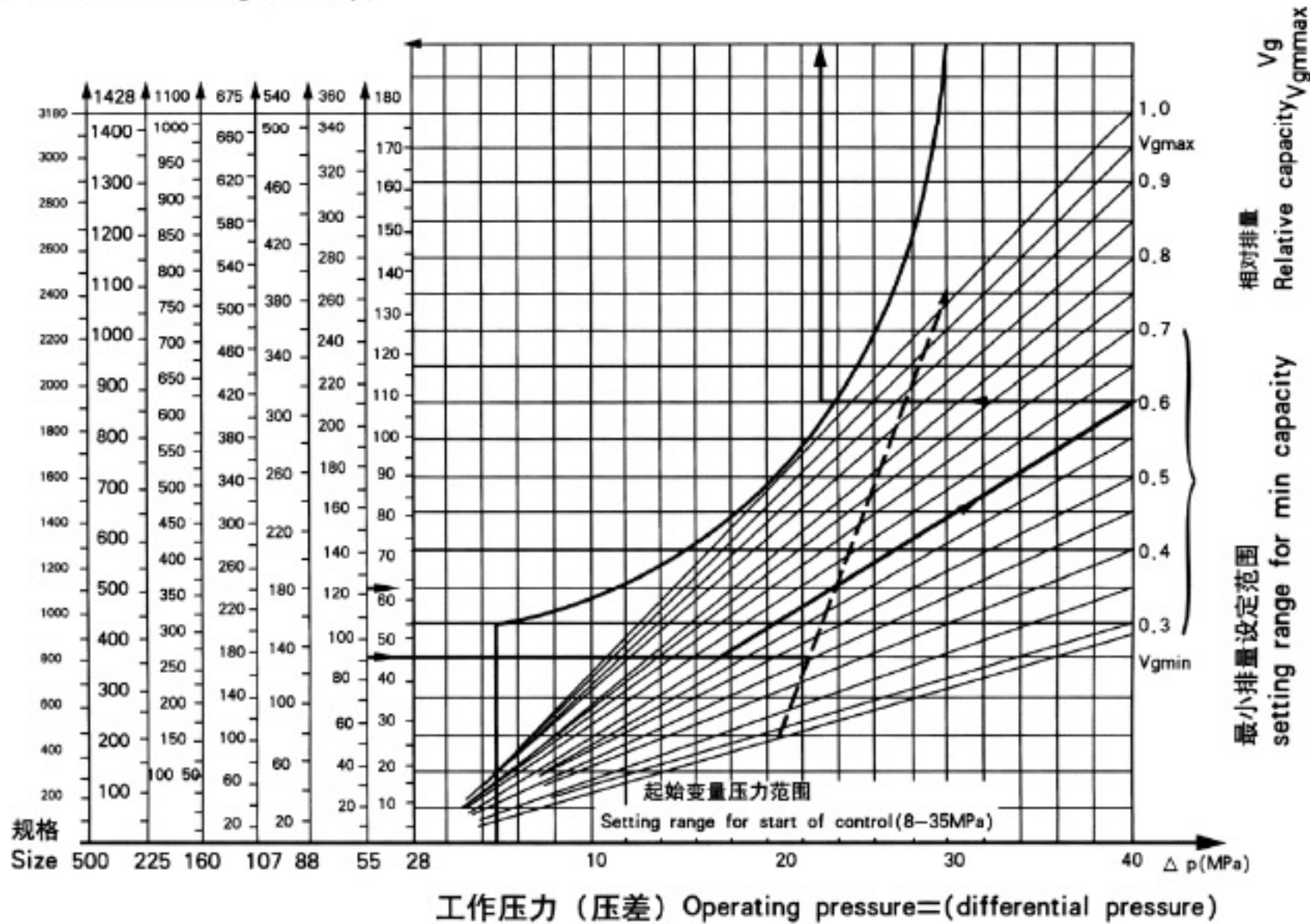

应用示例 1

规格 55; HA1

变量起点压力设定为 17MPa 从 V_{gmin} 到 V_{gmax} 压力恒定, 输出扭矩 $M=90\text{Nm}$,

求: 马达排量和相对转速。

解:

对于 $M=90\text{Nm}$ 和 $\Delta P=17\text{MPa}$ 由图表 查出相对排量为

$$\frac{V_g}{V_{gmax}} = 0.6$$

和相对转速 $\frac{n}{n \text{ at } V_{gmax}} = 1.666$.

即在相同流量下马达的转速是在最大排量时约 1.666 倍。

这时的排量

$$V_g = 0.6 \times V_{gmax} = 0.6 \times 54.89 = 32.9\text{ml/r}$$

应用示例 2

规格 55; HA2

变量起点压力设定为 20MPa 从 V_{gmin} 到 V_{gmax} 压力升高 10MPa, 输出扭矩 $M=122\text{Nm}$,

求: 马达排量工作压力和相对转速。

解: 对 HA 的变量马达按下述步骤求解先找出起始变量压力 20MPa 时与 V_{gmin} 线的交点和变量终点压力 20MPa 时与 V_{gmin} 线的交点和变量终点压力 $20 + 10 = 30\text{MPa}$ 与 V_{gmin} 线的交点, 该两点的连线即为该马达的变量特性曲线。

当 $M=122\text{Nm}$ 时对应于该点的工作压力 $\Delta P=23.5\text{MPa}$, 相对排量为:

$$\frac{V_g}{V_{gmax}} = 0.6$$

相对转速为 $\frac{n}{n \text{ at } V_{gmax}} = 1.666$

$$\begin{aligned} \text{排量 } V_g &= 0.6 \times V_{gmax} \\ &= 0.6 \times 54.89 \\ &= 32.9\text{ml/r} \end{aligned}$$

Example 1

Size 55; HA 1

Start control set at 17MPa

Model without pressure increase from V_{gmin} to V_{gmax} .

Output torque $M=90\text{Nm}$

Required: Motor capacity and speed ratio

Solution: For a required output torque of 90 Nm and an operating pressure $\Delta P=17\text{MPa}$ a capacity ratio

$$\frac{V_g}{V_{gmax}} = 0.6 \text{ and a speed ratio}$$

$\frac{n}{n \text{ at } V_{gmax}} = 1.666$, is obtained i.e.

at the same oil flow, the variable motor rotates at a factor of 1.666 faster than at max capacity V_{gmax} .

The capacity ratio

$$\begin{aligned} V_g &= 0.6 \times V_{gmax} = 0.6 \times 54.89 \\ &= 32.9\text{ml/r} \end{aligned}$$

Example 2

Size 55; HA2

Start of control set at 20MPa Model with pressure increase from V_{gmin} to V_{gmax} 10MPa. Required output torque $M=122\text{Nm}$.

Required: Motor capacity operating pressure and speed ratio.

Solution: For variable motor HA2 with pressure increase, other characteristics apply.

These are obtained as follows.

The intersection point between line V_{gmin} and the pressure line for the end of control (e.g. start of control 20 MPa pressure increase 10MPa=end of control 30 MPa) is taken.

These two points are joined by a straight line. This is the correct characteristic line. For the required output torque of 122 Nm in the example, an operating pressure of approx 23.5 MPa (3.5MPa pressure increase) and a capacity ratio of

$$\frac{V_g}{V_{gmax}} = 0.6$$

is obtained together with a speed ratio

$$\frac{n}{n \text{ at } V_{gmax}} = 1.666.$$

The capacity ratio

$$\begin{aligned} V_g &= 0.6 \times V_{gmax} \\ &= 0.6 \times 54.89 \\ &= 32.9\text{ml/r} \end{aligned}$$

A6V 变量马达 Variable Displacement Motor A6V

外形尺寸 Unit Dimensions 装配方式2

规格 Size 28-225

装配方式2 Assembly type 2

HD、HS变量 Control

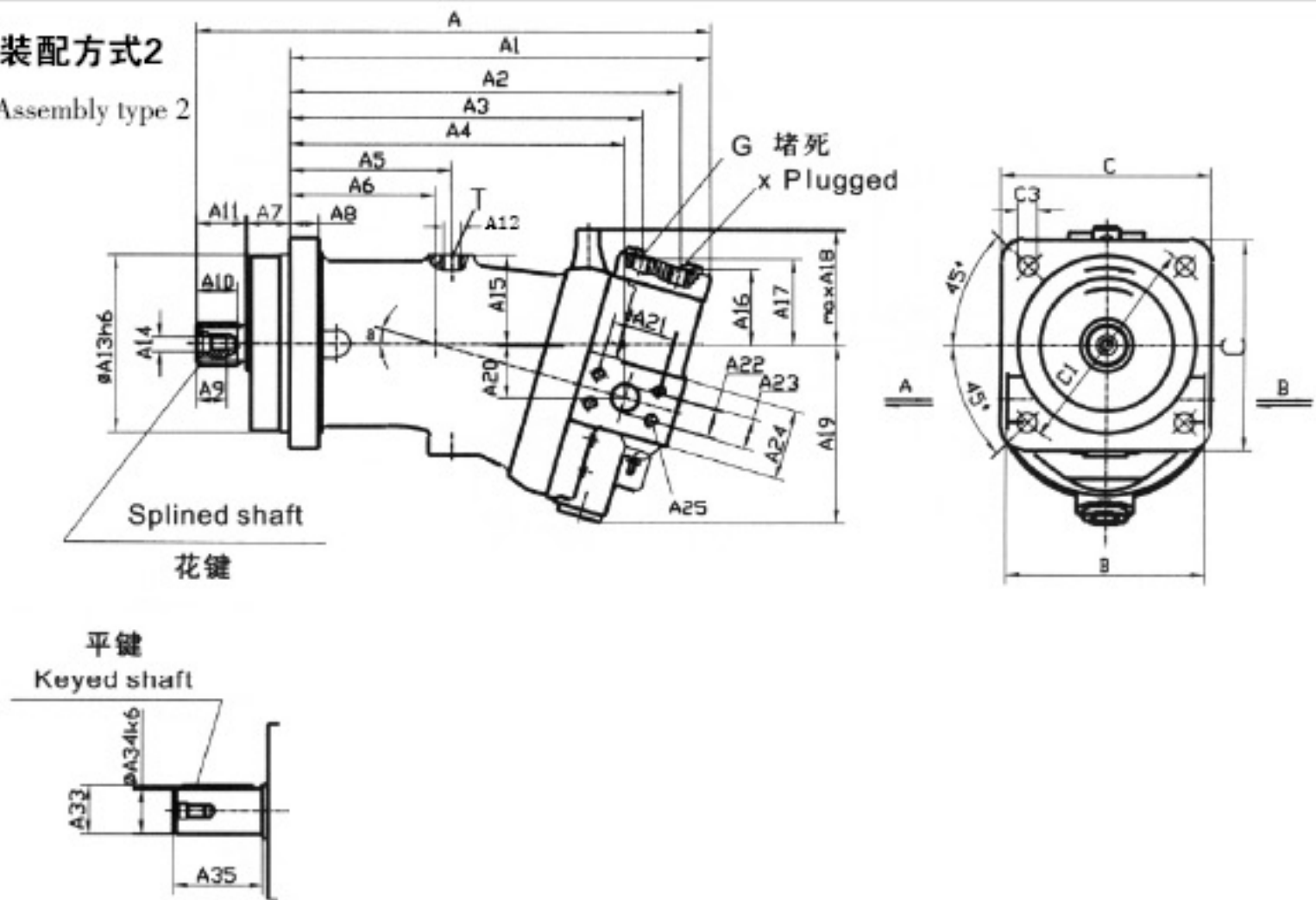

规格 Size 28-225

装配方式2 Assembly type 2

HD、HS变量 Control

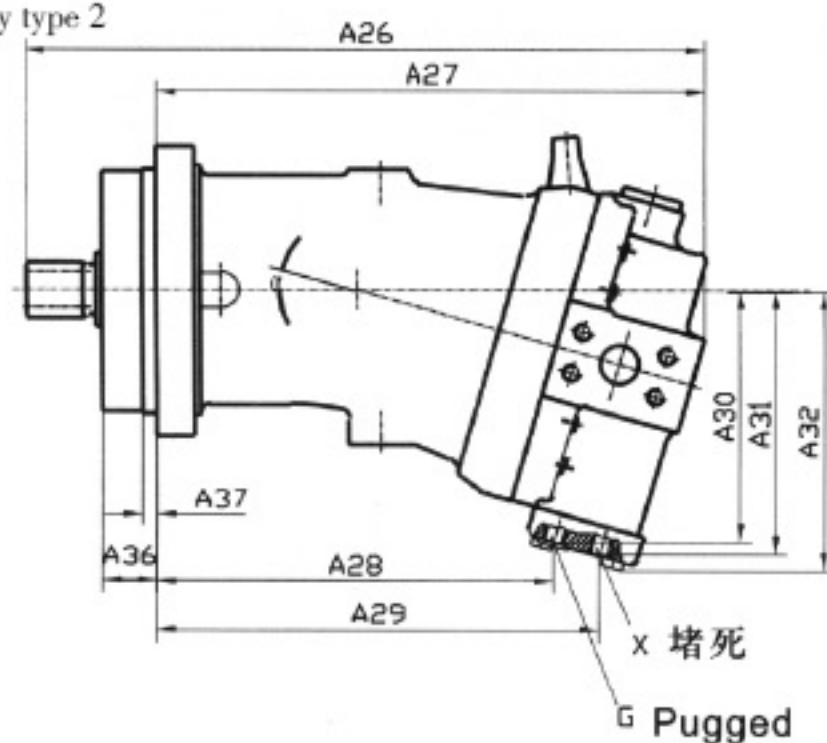

SAE 法兰连接 (压力油口)
螺纹连接 (压力油口)

SAE pressure port
Threaded pressure port

A,B,工作油口
G 多元件同步控制
和遥控压力油口
X 先导 (外控) 油口
T 壳体 · 油口

service port
port for synchronous control
of multiple units and for
remote control pressure.
pilot pressure
case drain

规格	深																													
Size	A	A ₁	A ₂	A ₃	A ₄	A ₅	A ₆	A ₇	A ₈	A ₉	A ₁₀	A ₁₁	A ₁₂	A ₁₃	A ₁₄	A ₁₅	A ₁₆	A ₁₇	A ₁₈	A ₁₉	A ₂₀	A ₂₁	A ₂₂	A ₂₃	A ₂₄	A ₂₅	deep	A ₂₆	A ₂₇	A ₂₈
28	317	249	230	206	189	107	75	25	16	19	28	43M16 × 1.5	100	M8	50	57	64	81	110	33	50.8	20	23.8	45	M10	17	298	230	152	
55	379	312	291	264	249	123	108	32	20	28	28	35M18 × 1.5	125	M12	63	52	60	84	132	40	50.8	20	23.8	53	M10	17	368	301	208	
80	440	368	345	316	297	152	137	32	23	28	33	40M18 × 1.5	140	M12	71	59	68	99	150	46	57.2	25	27.8	64	M12	18	425	353	252	
107	463	378	356	326	301	145	130	40	25	28	37.5	45M18 × 1.5	160	M12	80	63	71	104	162	49	57.2	25	27.8	64	M12	18	442	357	259	
160	530	440	412	377	354	213	156	40	28	36	42.5	50M22 × 1.5	180	M16	88	66	77	108	182	57	66.7	32	31.8	70	M14	19	513	423	302.5	
225	573	468	441	405	375	222	162	50	32	36	43.5	55M22 × 1.5	200	M16	96	74	85	121	199	61	66.7	32	31.8	70	M14	21	546	441	324	

规格											平键	花键	花键							
Size	A ₂₉	A ₃₀	A ₃₁	A ₃₂	A ₃₃	A ₃₄	A ₃₅	A ₃₆	A ₃₇	B	B ₁	C	C ₁	C ₂	C ₃	GB1096-79	DIN 5480	GB3478.1-83	G	X
28	176	124	131	139	27.9	25	50	23	8	116	M27 × 2	118	125	12	11	键 8 × 50	W25 × 1.25 × 18 × 9g	EXT18Z × 1.25M × 30P × 5h	M12 × 1.5	M14 × 1.5
55	235	133	141	153	32.9	30	60	29	10	142	M33 × 2	150	160	16	13.5	键 8 × 50	W30 × 2 × 14 × 9g	EXT14Z × 2m × 30P × 5h	M14 × 1.5	M14 × 1.5
80	282	152	161	177	38	35	70	29.5	10	172	M42 × 2	165	180	16	13.5	键 10 × 56	W35 × 2 × 16 × 9g	EXT16Z × 2m × 30P × 5h	M14 × 1.5	M14 × 1.5
107	288	164	173	188	43.1	40	80	35	10	178	M42 × 2	190	200	20	17.5	键 12 × 63	W40 × 2 × 18 × 9g	EXT18Z × 2m × 30P × 5h	M14 × 1.5	M14 × 1.5
160	338	182.5	193	201	48.5	45	90	36.5	11.5	208	M48 × 2	210	224	20	17.5	键 14 × 70	W45 × 2 × 21 × 9g	EXT21Z × 2m × 30P × 5h	M14 × 1.5	M14 × 1.5
225	359	201	211	219	53.5	50	100	50	12	226	M48 × 2	236	250	25	22	键 14 × 80	W50 × 2 × 24 × 9g	EXT24Z × 2m × 30P × 5h	M14 × 1.5	M14 × 1.5

A6V 变量马达 Variable Displacement Motor A6V

DA 变量 Control

装配方式2 Assembly type2

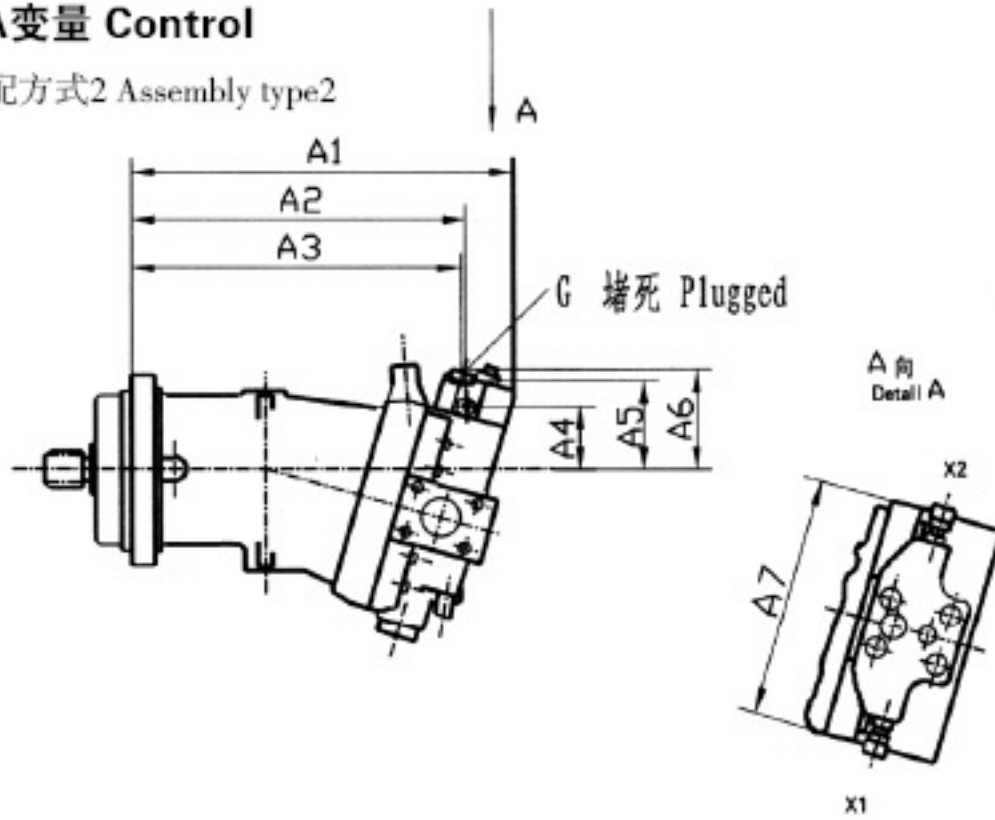

规格

Size	A ₁	A ₂	A ₃	A ₄	A ₅	A ₆	A ₇	X ₁ , X ₂
28	253	212	209	53	73	81	144	M14 × 1.5
55	317	272	268	49	70	77	146	M14 × 1.5
80	371	326	322	56	77	83	152	M14 × 1.5
107	380	336	332	59	81	88	152	M14 × 1.5
160	442	387	383	65	86	94	158	M14 × 1.5
225	471	416	411	73	95	103	158	M14 × 1.5

其余尺寸见 HD/HA.

Other dimensions see HD/HA.

EP 变量 Control

装配方式2
Assembly type 2

装配方式1
Assembly type 1

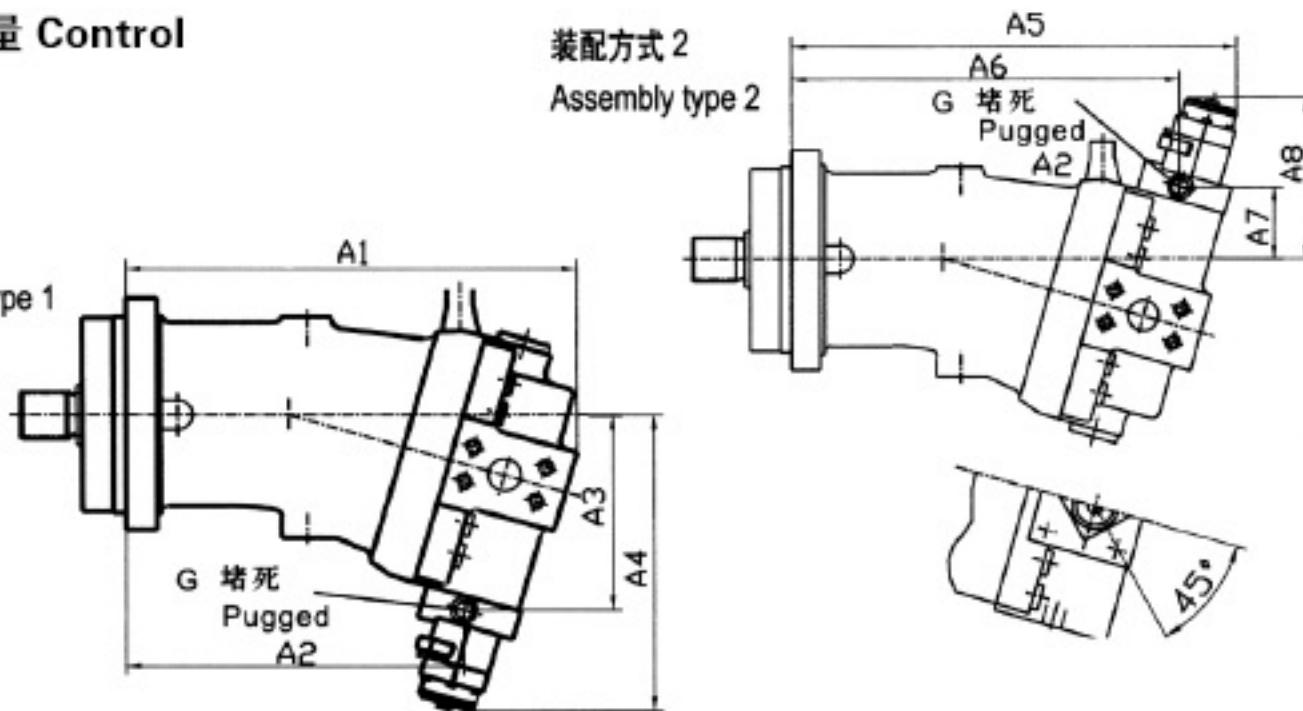

规格

Size	A ₁	A ₂	A ₃	A ₄	A ₅	A ₆	A ₇	A ₈
28	230	164	119	204	266	212	53	131
55	301	223	129	213	334	274	48	124
80	353	267	148	240	392	326	56	137
107	357	269.5	160	254	393	333	61.5	144
160	423	313	177	265	452	386	70	139
225	441	334	196	284	481	414	74.5	147

其余尺寸见 HD/HA.

Other dimensions see HD/HA

MA 变量 Control

装配方式1 Assembly type 1

装配方式2 Assembly type 2

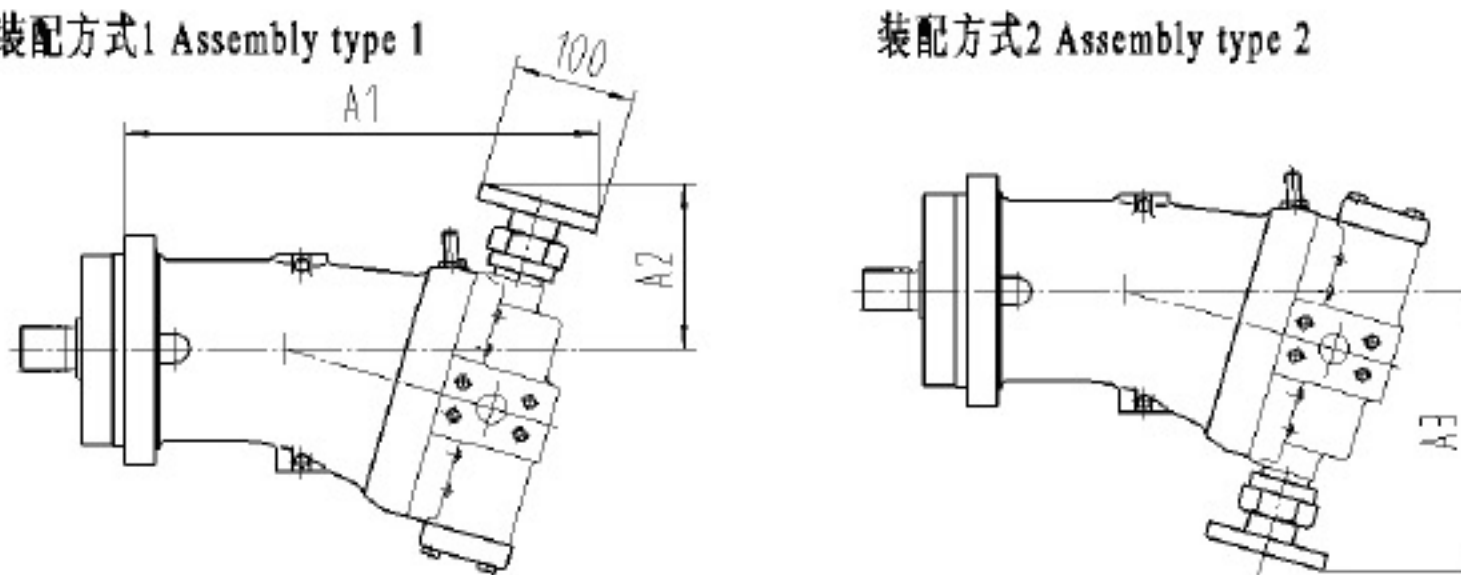

规格

Size	A1	A2	A3
28	269	128	188
55	329	134	208
80	381	138	223
107	390	137	230
160	441	149	254
225	470	155	272

其余尺寸见HD/HA

Other dimensions see HD/HA

HD1D 变量 Control

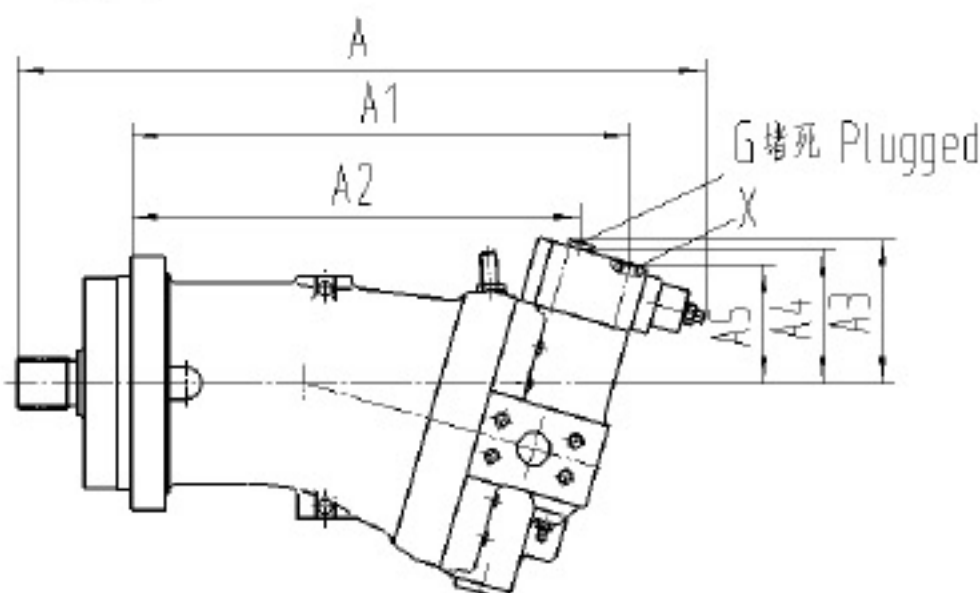

规格

Size	A	A1	A2	A3	A4	A5	X
80	491	363	325	105	97	85	G1/4
107	514	373	336	108	100	88	G1/4
160	576	421	386	118	109	98	G1/4

其余尺寸见HD/HA

Other dimensions see HD/HA

A6V 变量马达 Variable Displacement Motor A6V

MO 变量 Control

装配方式1 Assembly type

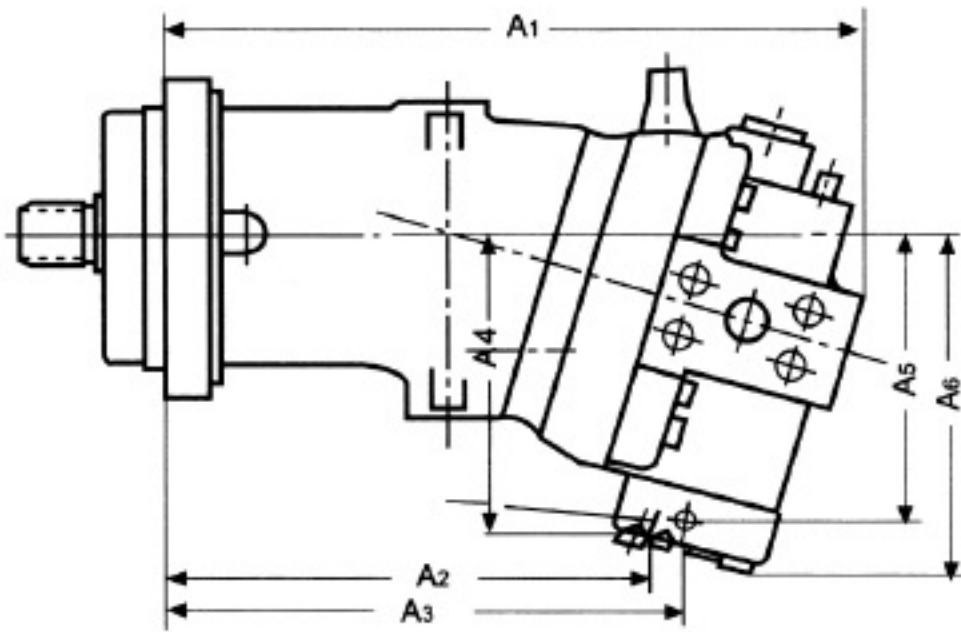
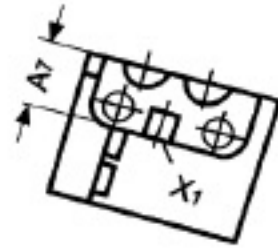

规格

Size	A ₁	A ₂	A ₃	A ₄	A ₅	A ₆	A ₇	X ₁
55	301	208	224	138	130	155	30	M14 × 1.5
80	353	252	268	157	149	177	33	M14 × 1.5
107	357	257	273	169	161	188	33	M14 × 1.5
160	423	300	312	187	178	206	34	M14 × 1.5
225	441	322	334	206	197	225	34	M14 × 1.5

其余尺寸见 HD/HA.

Other dimensions see HD/HA.

外形尺寸 Unit Dim dimensions

规格 Size 500

HA 变量 Control

花键 Splined

W70 × 3 × 22 × 9g

(DIN 5480)

装配方式1 Assembly

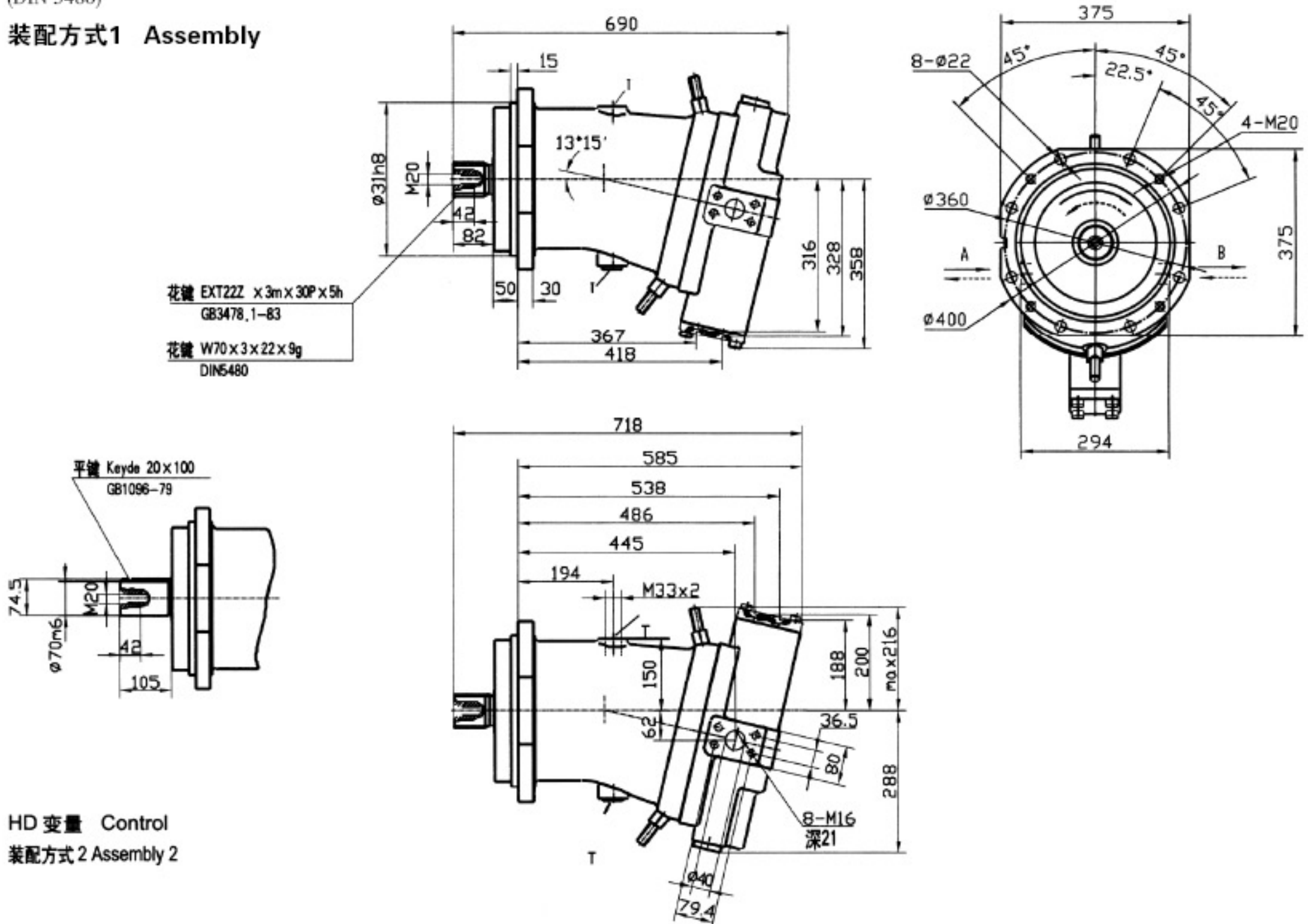

HD 变量 Control

装配方式2 Assembly 2