

RE 50131

Ausgabe: 2021-10

Ersetzt: 2020-10

Accumulator shut-off block

Type ABZSS

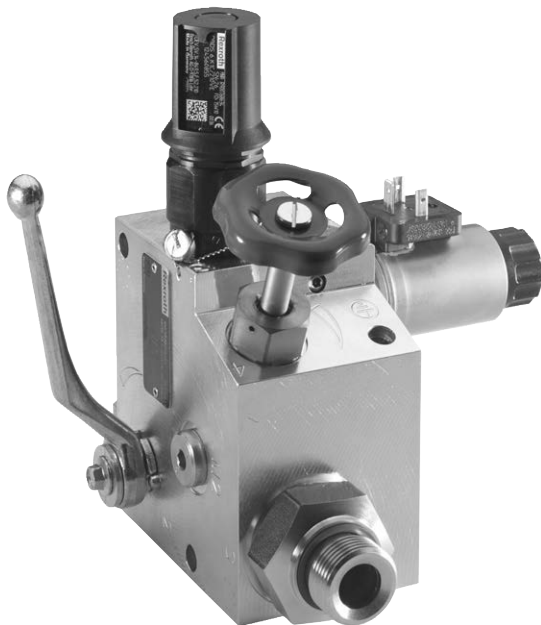

HAD8066

- ▶ Nominal diameter DN08; DN10; DN20; DN30
- ▶ Component series 3X
- ▶ Maximum operating pressure 350 bar [5075 psi]

Contents

Features	1
Ordering code	2, 3
Symbols, function	4
Preferred types	5, 6
Technical data	7
Characteristic curves	8
Dimensions	9 ... 14
Special versions	15
Tightening torque	16
Mating connectors	16
Accessories	17 ... 20

**Type-examination tested safety valves type DBD...E
according to Pressure Equipment Directive 2014/68/EU
(in the following shortly PED)**

Safety instructions	20
Characteristic curves	21 ... 25
Further information	26

Ordering code

01	02	03	04	05	06	07	08	09	10	11	12	13	14
ABZSS				- 3X	/	E	/					-	*

01	Accumulator shut-off block	ABZSS
----	----------------------------	--------------

Type of connection

02	Piping connection	no code
	Subplate mounting	-P ¹⁾

Nominal diameter

03	DN08	08
	DN10	10
	DN20	20
	DN30	30

Unloading

04	Manual	M
	Manual and electro-magnetic (without manual override), normally open	E ²⁾
	Manual and electro-magnetic, normally closed	C ²⁾

Component series

05	Component series 30 ... 39 (30 ... 39: unchanged installation and connection dimensions)	3X
----	--	-----------

Pressure adjustment (others upon request)

06	50 bar [730 psi]	50
	100 bar [1450 psi]	100
	140 bar [2030 psi]	140
	210 bar [3050 psi]	210
	350 bar [5075 psi]	350 ³⁾

Pressure relief valve

07	Pressure relief valve, type-examination tested (with CE mark) ⁴⁾	E
----	---	----------

Accumulator adapter

08	Without accumulator adapter	no code
	- With BSP thread G1/2	
	DN08	S104
	DN10; DN20	S30
	- With BSP thread G3/4	
	DN08	S108
	DN10; DN20	S31
	DN08	S105
	DN10; DN20	S10
	- With BSP thread G1 1/4	
	DN08	S107
	DN10; DN20	S12
	DN30	S307
	- With BSP thread G2	
	DN08	S109
	DN10; DN20	S13
	DN30	S309

 **Notice:** Preferred types and standard units are contained in the EPS (standard price list).

Ordering code

01	02	03	04	05	06	07	08	09	10	11	12	13	14
ABZSS				-	3X	/		E	/			-	*

Accumulator adapter

08	- With SAE thread 3/4 - 16 UNF		
	DN10; DN20		S64
	- With SAE thread 1 1/16 - 12 UN		
	DN10; DN20		S60
	- With SAE thread 1 5/8 - 12 UN		
	DN10; DN20		S62
	DN30		S620
	- With SAE thread 1 7/8 - 12 UN		
DN10; DN20		S63	
DN30		S630	

Voltage type ⁵⁾

09	Direct voltage 24 V	G24
	Alternating voltage 110 V	G96 ⁸⁾
	Alternating voltage 230 V	G205 ⁸⁾

Electrical connection ⁵⁾

10	Without mating connector with protective cap	K4 ⁶⁾
----	---	-------------------------

Seal material

11	FKM seals	V
	NBR seals	W ⁷⁾

Connection thread

12	BSP thread (ISO 228 Part 1)	no code
	SAE thread (ANSI B1.1)	12 ²⁾

Special versions

13	- DN30 with DBDS valve NG30	SO30
	- Shut-off device (2 positions) DN10 ... DN30	103
	- Shut-off device (1 position) DN10 ... DN30	104
	- Prepared for use in mining and explosion protection applications	869 ⁹⁾

Connection thread

14	Further details in the plain text	
----	-----------------------------------	--

1) "DN30" only

2) Not with "DN08"

3) Type SO30 is supplied with a pressure rating of 315 bar [4570 psi]

4) According to the Pressure Equipment Directive 2014/68/EU

5) Only with electro-magnetic unloading design "E" or electro-magnetic pressure holding design "C"

6) Mating connectors, separate order, see page 16 and data sheet 08006.

7) Special version

8) For the connection to the AC voltage mains, a DC solenoid which is controlled by a rectifier is to be used (see table on the right). For individual connection, a large mating connector with integrated rectifier can be used (separate order, see page 16).

9) Manual accumulator discharge only, seal material "V" only. Assembly free from aluminum, without electrically operated components, housing electroplated FE//Zn8//Cn//T0 according to ISO 19598

AC voltage mains (admissible voltage tolerance $\pm 10\%$)	Nominal voltage of the DC solenoid in case of operation with alternating voltage	Ordering code
110 V - 50/60 Hz 120 V - 60 Hz	96 V	G96
230 V - 50/60Hz	205 V	G205

 **Notice:** Unlike the ABZSS30 standard accumulator safety block, the ABZSS30 ...SO30 is equipped with a direct operated pressure relief valve NG30. Version ABZSS-P30 for subplate mounting.

Symbols

DN08

Version "M" (manual unloading)

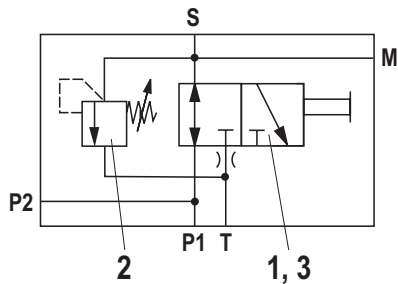

DN10, 20 and 30

Version "M" (manual unloading)

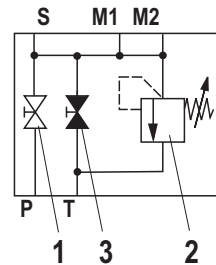

Version "E"

(manual and electro-magnetic unloading), normally open

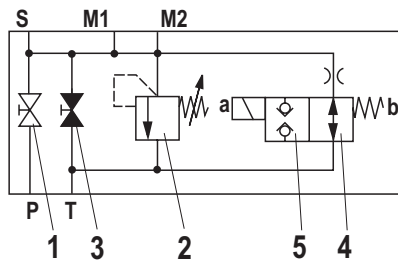

Connection designation	
M; M1; M2	Measuring port
P; P1; P2	Pump port
S	Accumulator port
T	Tank port
1	System shut-off cock
2	Pressure relief valve
3	Manual unloading
4	Electro-magnetic unloading, normally open, optional
5	Electro-magnetic unloading, normally closed, optional

Function

The accumulator shut-off block serves for the protection, isolation and unloading of hydraulic accumulators. It is classified based on its use according to the Pressure Equipment Directive 2014/68/EU article 4, section 3. The connection between the accumulator shut-off block and the accumulator is realized by means of an accumula-

tor adapter.

The accumulator is protected from inadmissible overpressure by means of the pressure relief valve. The **pressure relief valve** must **not be used for any control tasks**. Sufficient difference between the maximum operating pressure and the working pressure must be ensured. Response of the pressure relief valve should be prevented, if possible.

Preferred types

Accumulator type	Data sheet	Accumulator NG in l [gal]	Pressure set at the pressure relief valve in bar [psi]	Accumulator shut-off block DN	Denomination	Material no.
Diaphragm type accumulator	50150	0.5 [0.13]	160 [2320]	08	ABZSS 08 M-3X/160E/S104V	R901263004
				10	ABZSS 10 M-3X/160E/S30V	R900711145
		0.7 [0.18]	180 [2610]	08	ABZSS 08 M-3X/180E/S104V	R901263013
				10	ABZSS 10 M-3X/180E/S30V	R904100876
			250 [3625]	08	ABZSS 08 M-3X/260E/S104V	R901263011
				10	ABZSS 10 M-3X/260E/S30V	R901147802
		1.0 [0.26]	200 [2900]	08	ABZSS 08 M-3X/200E/S104V	R901263012
				10	ABZSS 10 M-3X/200E/S30V	R904100849
		1.4 [0.37]	140 [2030]	08	ABZSS 08 M-3X/140E/S104V	R901263020
				10	ABZSS 10 M-3X/140E/S30V	R900711138
			250 [3625]	08	ABZSS 08 M-3X/260E/S104V	R901263011
				10	ABZSS 10 M-3X/260E/S30V	R901147802
		2.0 [0.53]	100 [1450]	08	ABZSS 08 M-3X/100E/S108V	R901263014
				10	ABZSS 10 M-3X/100E/S31V	R900711131
			250 [3625]	08	ABZSS 08 M-3X/260E/S108V	R901263015
				10	ABZSS 10 M-3X/260E/S31V	R901147799
		2.8 [0.74]	70 [1015]	08	ABZSS 08 M-3X/070E/S108V	R901263016
				10	ABZSS 10 M-3X/070E/S31V	R901259516
			250 [3625]	08	ABZSS 08 M-3X/260E/S108V	R901263015
				10	ABZSS 10 M-3X/260E/S31V	R901147799
3.5 [0.91]	250 [3625]	08	ABZSS 08 M-3X/260E/S108V	R901263015		
		10	ABZSS 10 M-3X/260E/S31V	R901147799		
Bladder-type accumulator	50170	1.0 [0.26]	350 [5075]	08	ABZSS 08 M-3X/350E/S105V	R901263022
				10	ABZSS 10 M-3X/350E/S10V	R901259519
				08	ABZSS 08 M-3X/350E/S107V	R901272573
				10	ABZSS 10 M-3X/350E/S12V	R901272576
				08	ABZSS 08 M-3X/350E/S107V	R901272573
				10	ABZSS 10 M-3X/350E/S12V	R901272576
		2.5 [0.66]	350 [5075]	08	ABZSS 08 M-3X/350E/S107V	R901272573
				10	ABZSS 10 M-3X/350E/S12V	R901272576
		4.0 [1.06]	350 [5075]	08	ABZSS 08 M-3X/350E/S107V	R901272573
				10	ABZSS 10 M-3X/350E/S12V	R901272576
		6.0 [1.56]	350 [5075]	08	ABZSS 08 M-3X/350E/S107V	R901272573
				10	ABZSS 10 M-3X/350E/S12V	R901272576
10 [2.64]	350 [5075]	20	ABZSS 20 M-3X/330E/S13V	R900711415		
		30	ABZSS 30 M-3X/330E/S 309V	R900713383		
ABZSS-P 30 M-3X/330E/S309V	R901146459					
ABZSS 30 M-3X/330E/S 309V	R900713383					
ABZSS-P 30 M-3X/330E/S309V	R901146459					
20 [5.28]	350 [5075]	20	ABZSS 20 M-3X/330E/S13V	R900711415		
		30	ABZSS 30 M-3X/330E/S 309V	R900713383		
ABZSS-P 30 M-3X/330E/S309V	R901146459					
ABZSS 30 M-3X/330E/S 309V	R900713383					
ABZSS-P 30 M-3X/330E/S309V	R901146459					
32 [8.45]	330 [4785]	30	ABZSS 30 M-3X/330E/S 309V	R900713383		
			ABZSS-P 30 M-3X/330E/S309V	R901146459		
50 [13.2]	330 [4785]	30	ABZSS 30 M-3X/330E/S 309V	R900713383		
			ABZSS-P 30 M-3X/330E/S309V	R901146459		

 **Notice:** Preferred types and standard units are contained in the EPS (standard price list).

Preferred types

Accumulator type	Data sheet	Accumulator NG in l [gal]	Pressure set at the pressure relief valve in bar [psi]	Accumulator shut-off block DN	Denomination	Material no.
Diaphragm type accumulator	50150	0.5 [0.13]	160 [2320]	10	ABZSS 10 E-3X/160E/S30G 24K4V	R901263026
		0.7 [0.18]	180 [2610]	10	ABZSS 10 E-3X/180E/S30G 24K4V	R901263028
			250 [3625]	10	ABZSS 10 E-3X/260E/S30G 24K4V	R901147797
		1.0 [0.26]	200 [2900]	10	ABZSS 10 E-3X/200E/S30G 24K4V	R900709591
		1.4 [0.37]	140 [2020]	10	ABZSS 10 E-3X/140E/S30G 24K4V	R900709589
			250 [3625]	10	ABZSS 10 E-3X/260E/S30G 24K4V	R901147797
		2.0 [0.53]	100 [1450]	10	ABZSS 10 E-3X/100E/S31G 24K4V	R900709586
			250 [3625]	10	ABZSS 10 E-3X/260E/S31G 24K4V	R900709604
		2.8 [0.74]	70 [1015]	10	ABZSS 10 E-3X/070E/S31G 24K4V	R901263029
			250 [3625]	10	ABZSS 10 E-3X/260E/S31G 24K4V	R900709604
3.5 [0.91]	250 [3625]	10		ABZSS 10 E-3X/260E/S31G 24K4V	R900709604	
Bladder-type accumulator	50170	1.0 [0.26]	350 [5075]	10	ABZSS 10 E-3X/350E/S10G 24K4V	R901263027
		2.5 [0.66]		10	ABZSS 10 E-3X/350E/S12G 24K4V	R901272591
		4.0 [1.06]		10	ABZSS 10 E-3X/350E/S12G 24K4V	R901272591
		6.0 [1.56]		10	ABZSS 10 E-3X/350E/S12G 24K4V	R901272591
		10 [2.64]	330 [4785]	20	ABZSS 20 E-3X/330E/S13G 24K4V	R900709636
		20 [5.28]			30	ABZSS 30 E-3X/330E/S 309G 24K4V
		32 [8.45]		ABZSS-P 30 E-3X/330E/S 309G 24K4V		R901147879
				ABZSS 30 E-3X/330E/S 309G 24K4V		R900709657
		50 [13.2]		ABZSS-P 30 E-3X/330E/S 309G 24K4V	R901147879	

 **Notice:** Preferred types and standard units are contained in the EPS (standard price list).

Technical data

(For application outside these values, please consult us!)

general							
Nominal diameter	DN	08	10	20	30	30S030	P30...
Weight	▶ Version "M"	kg	4.0	5.2	8.5	20.5	33.1
		[lbs]	[8.8]	[11.5]	[18.7]	[45.2]	[72.8]
	▶ Version "C" and "E"	kg	-	5.5	8.8	20.8	33.4
		[lbs]	-	[12.1]	[19.4]	[45.8]	[73.5]
Ambient temperature range	°C [°F]	-15 ... +80 [+5... +176]					

hydraulic	
Maximum operating pressure	bar [psi] 350 [5076]
Seal material	FKM seals or NBR seals ¹⁾
Block material	Steel
Hydraulic fluid	See table below
Maximum admissible degree of contamination of the hydraulic fluid Cleanliness class according to ISO 4406 (c)	Class 20/18/15 ²⁾
Hydraulic fluid temperature range	°C [°F] -10 ... +60 [+14... +140]
Viscosity range	mm ² /s [SUS] 12 ... 230 [55 ... 1066]

Hydraulic fluid	Classification	Suitable sealing materials	Standards	Data sheet
Mineral oils	HL, HLP	NBR, FKM	DIN 51524	90220

Important notices on hydraulic fluids:

- ▶ For more information and data on the use of other hydraulic fluids, please refer to the data sheets above or contact us.
- ▶ There may be limitations regarding the technical valve data

(temperature, pressure range, life cycle, maintenance intervals, etc.).

- ▶ The ignition temperature of the hydraulic fluid used must be 40 K higher than the maximum solenoid surface temperature.

electrical	
Protection class according to DIN EN 60529	▶ With connector "K4" IP 65 (with mating connector mounted and locked)

1) Special version

2) The cleanliness classes specified for the components must be adhered to in hydraulic systems. Effective filtration prevents faults and simultaneously increases the life cycle of the components.

Characteristic curves: Type-examination tested safety valves type DBD 1)

Size 6 (ABZSS 08, 10)

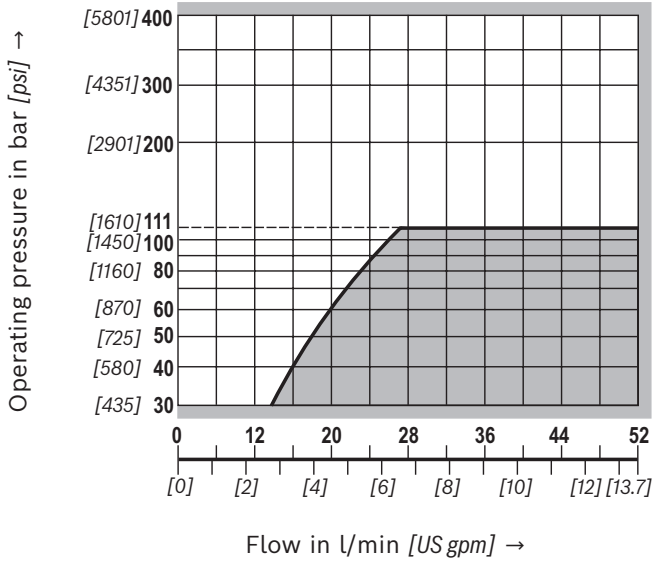

Size 10 (ABZSS 20)

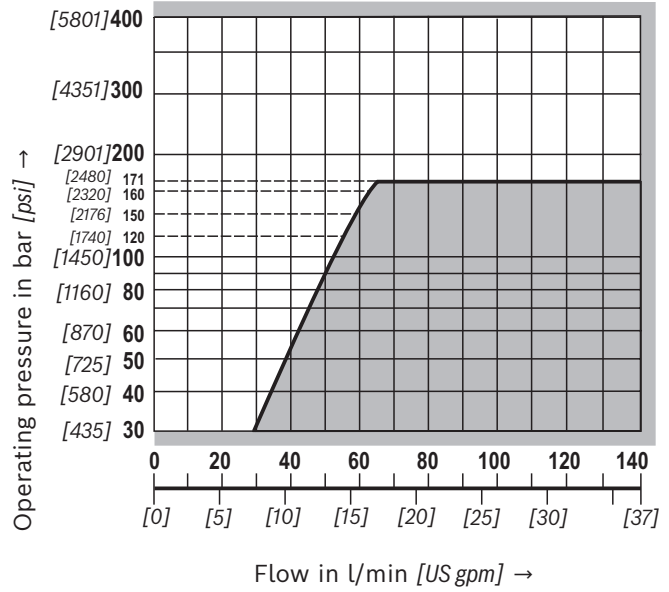

Size 20 (ABZSS 30, -P30)

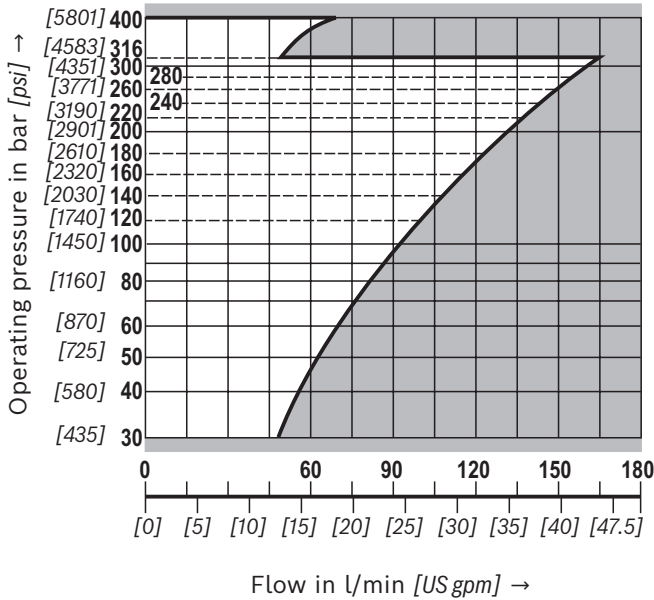

Size 30 (ABZSS 30...SO30)

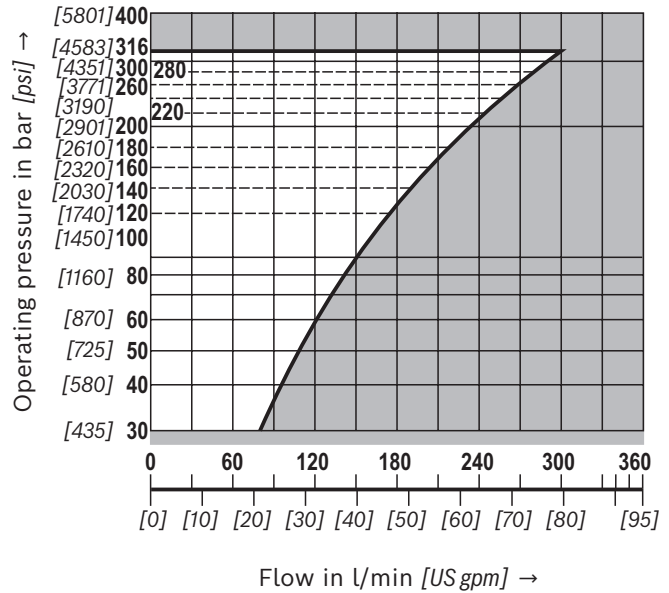

Notice:

Value pairs located in the areas of the characteristic curves with gray background can not be realized with the safety valve. The characteristic curves shown here are only valid for a counter pressure of 0 bar in the discharge line.

1) Component series 1X according to the Pressure Equipment Directive 2014/68/EU

Dimensions: Version "08..." (DN08)
(dimensions in mm [inch])

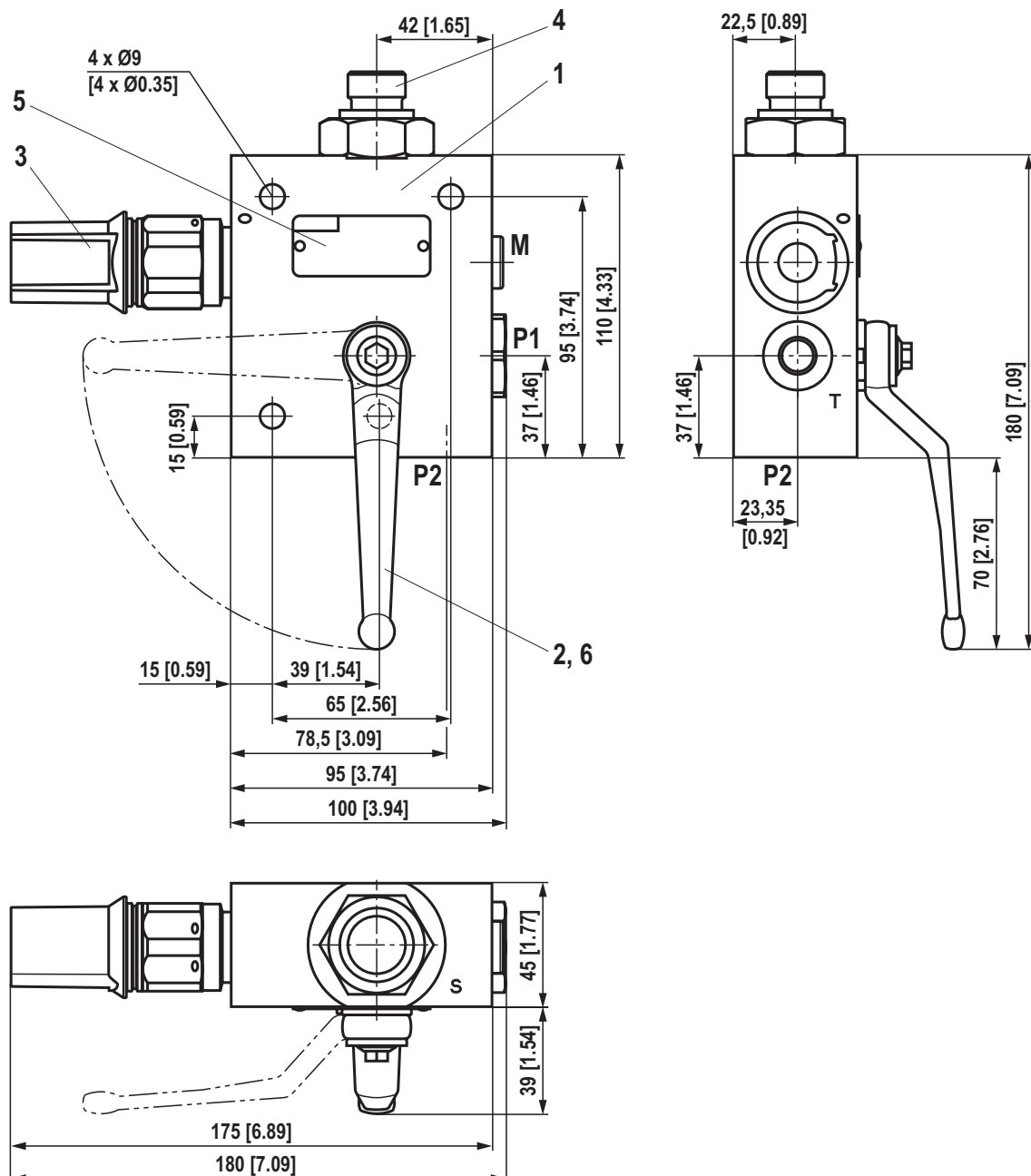

Connection thread		BSP
M1; M2	Measuring port	G1/4
P1	Pump port	G3/8
P2	Pump port	G1/2
T	Tank port	G1/4
S	Accumulator port	M20 x 1.5 ¹⁾

¹⁾ Mounting cavity according to DIN EN 9974-1

Item explanations see page [16](#)

Characteristic curves for type-examination tested safety valves type DBDS can be found on page [8](#)

Dimensions: Version "10..." (DN10)
(dimensions in mm [inch])

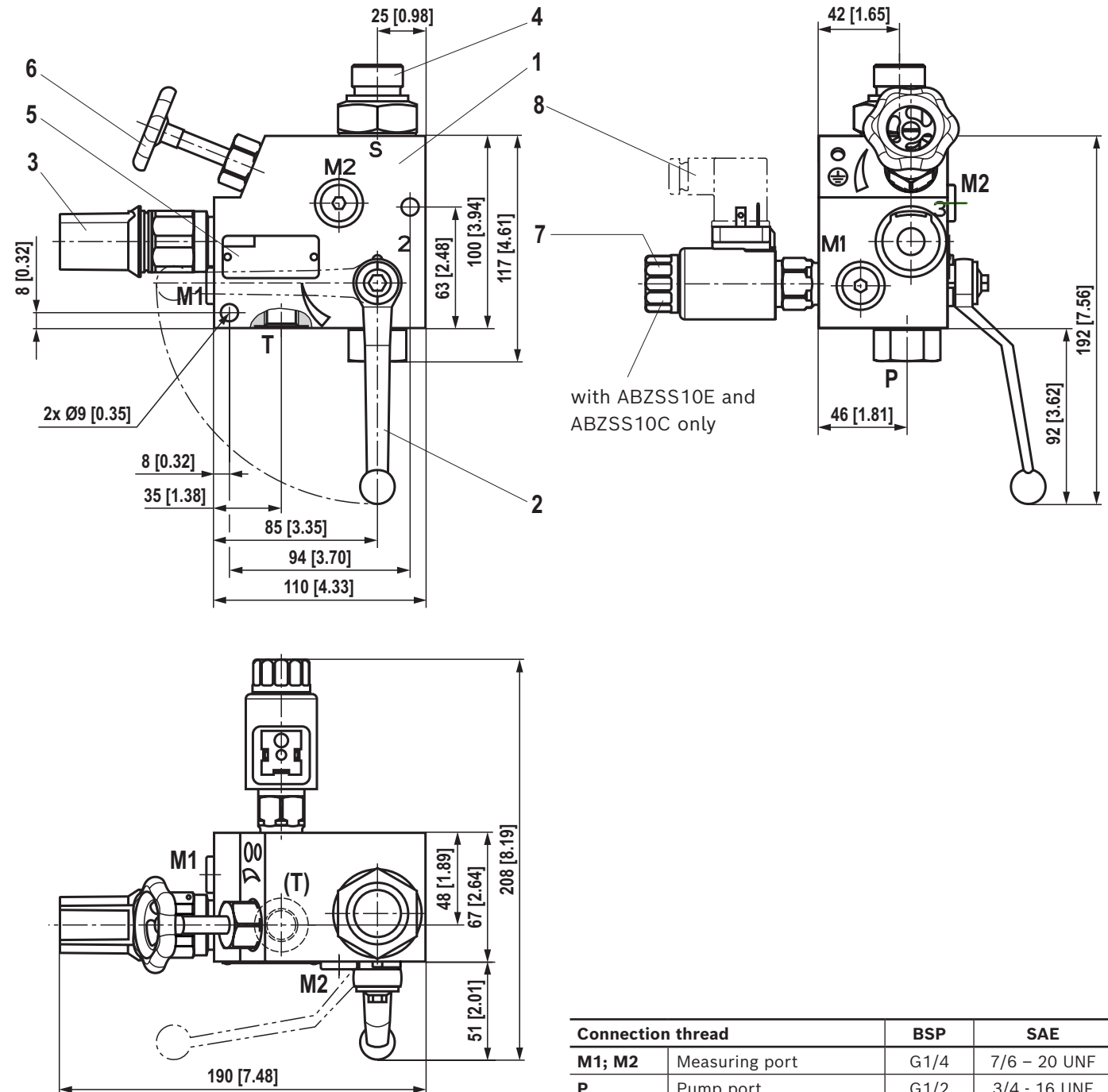

Item explanations see page 16

Characteristic curves for type-examination tested safety valves type DBDS can be found on page 8

Dimensions: Version "20..." (DN20)
(dimensions in mm [inch])

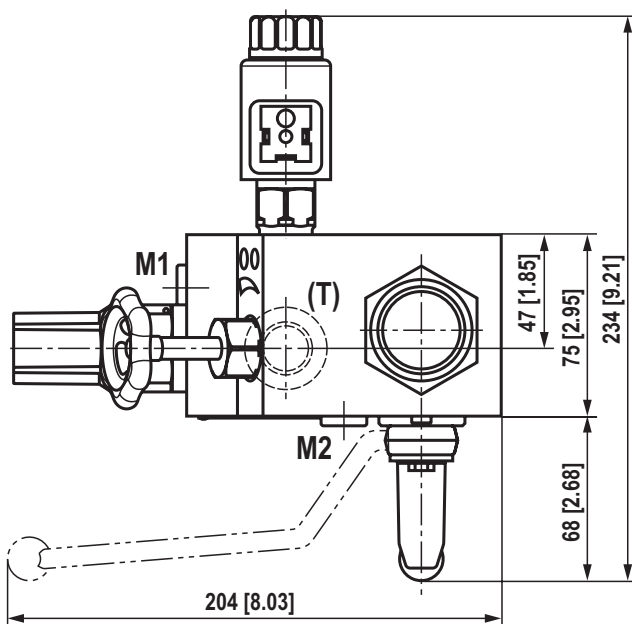
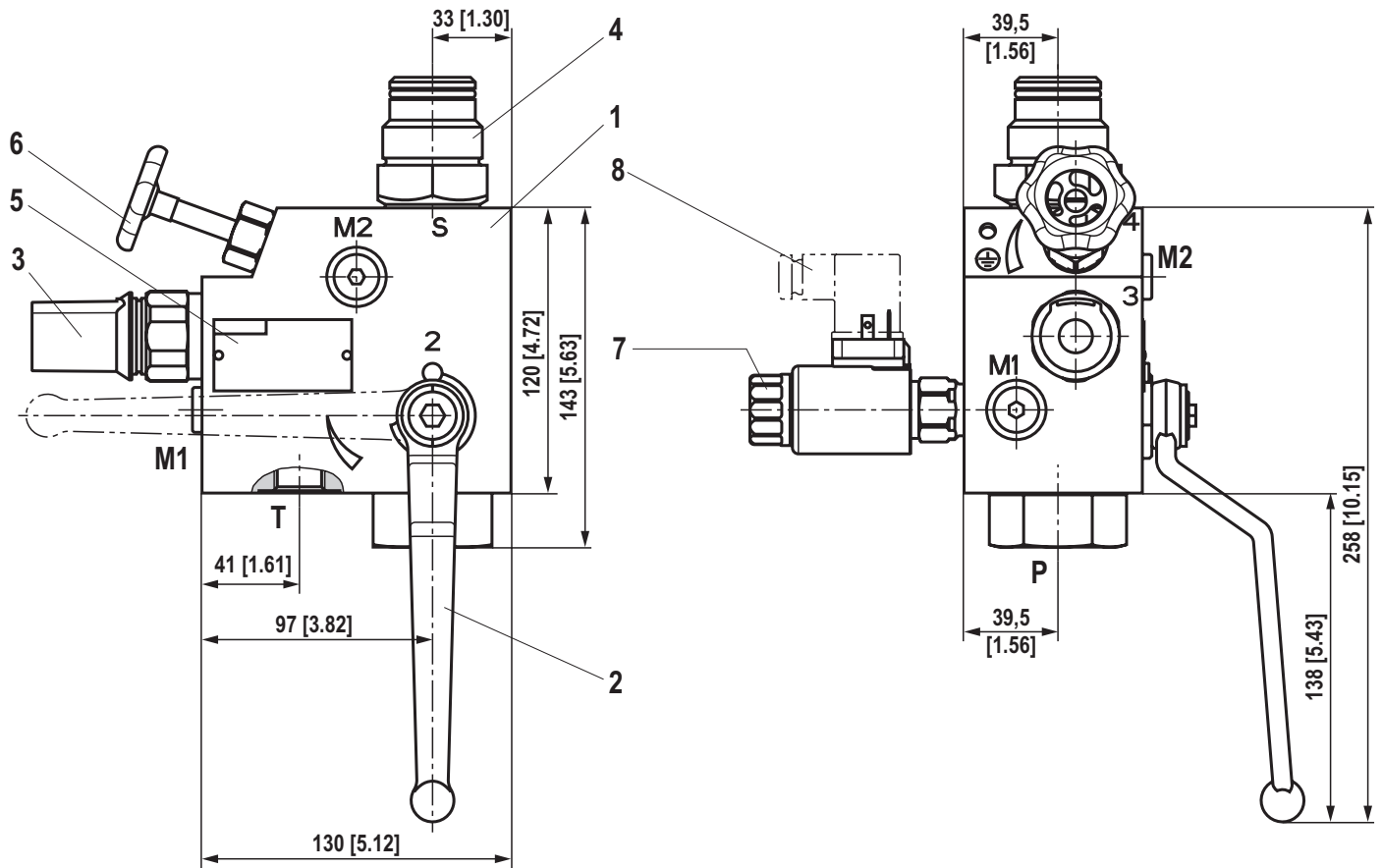

Connection thread		BSP	SAE
M1; M2	Measuring port	G1/4	7/6 - 20 UNF
P	Pump port	G1	1 5/16 - 12 UNF
T	Tank port	G1/2	3/4 - 16 UNF
S	Accumulator port	M33 x 2	M33 x 2

Item explanations see page 16

Characteristic curves for type-examination tested safety valves type DBDS can be found on page B

Dimensions: Version "30..." (DN30)
(dimensions in mm [inch])

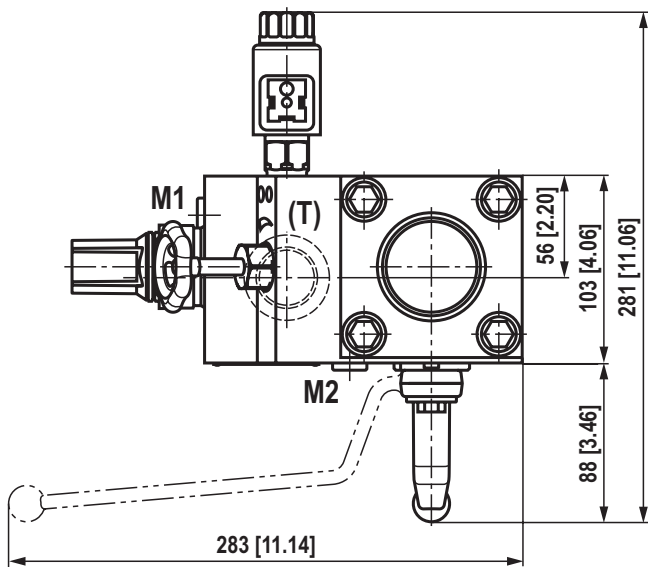
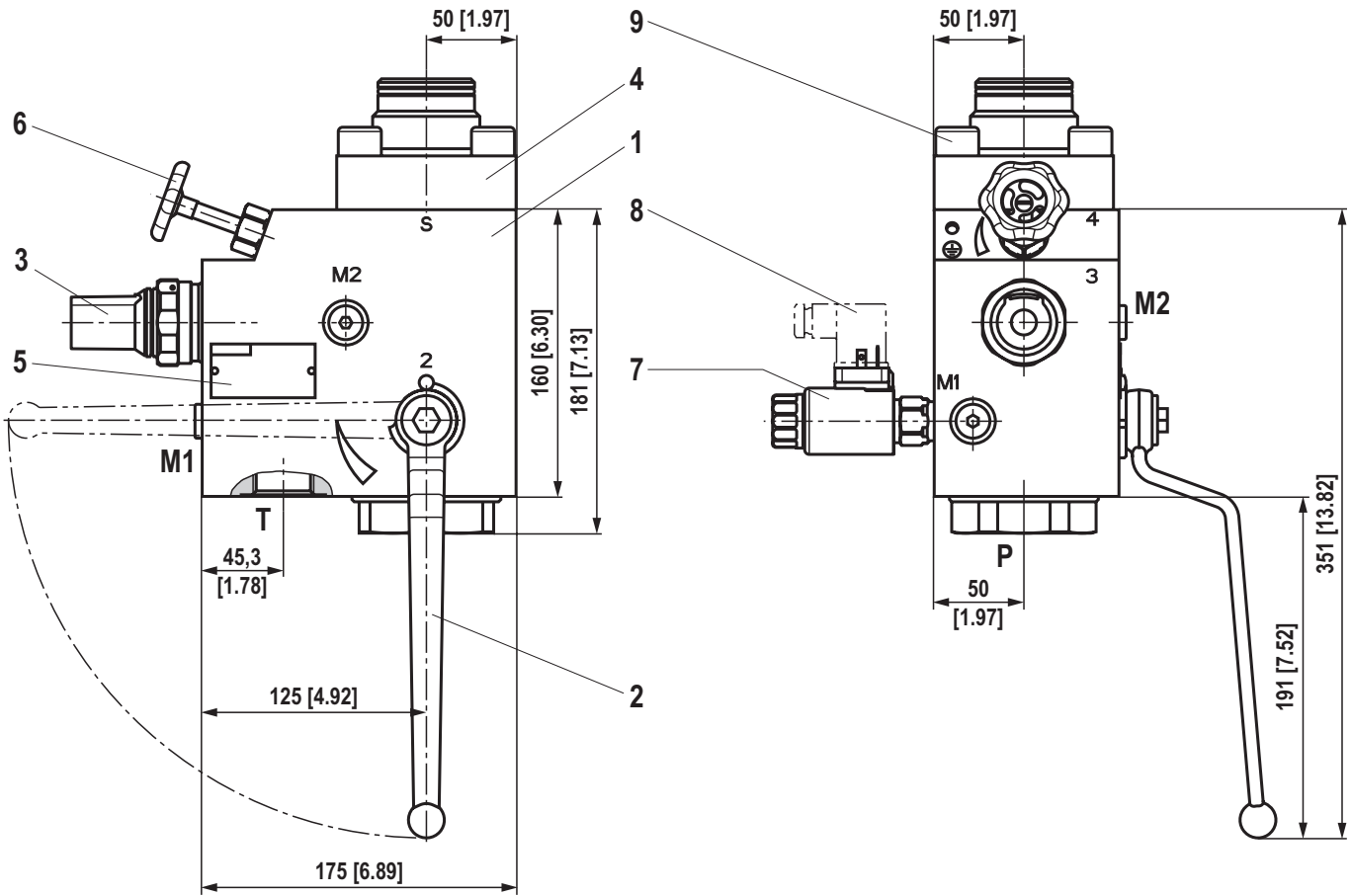

Connection thread		BSP	SAE
M1; M2	Measuring port	G1/4	7/6 - 20 UNF
P	Pump port	G1 1/2	1 7/8 - 12 UNF
T	Tank port	G1	1 5/16 - 12 UNF
S	Accumulator port (flange)	Page 16	Page 19

Item explanations see page 16

Characteristic curves for type-examination tested safety valves type DBDS can be found on page 8

Dimensions: Version "30...SO30" (DN30)
(dimensions in mm [inch])

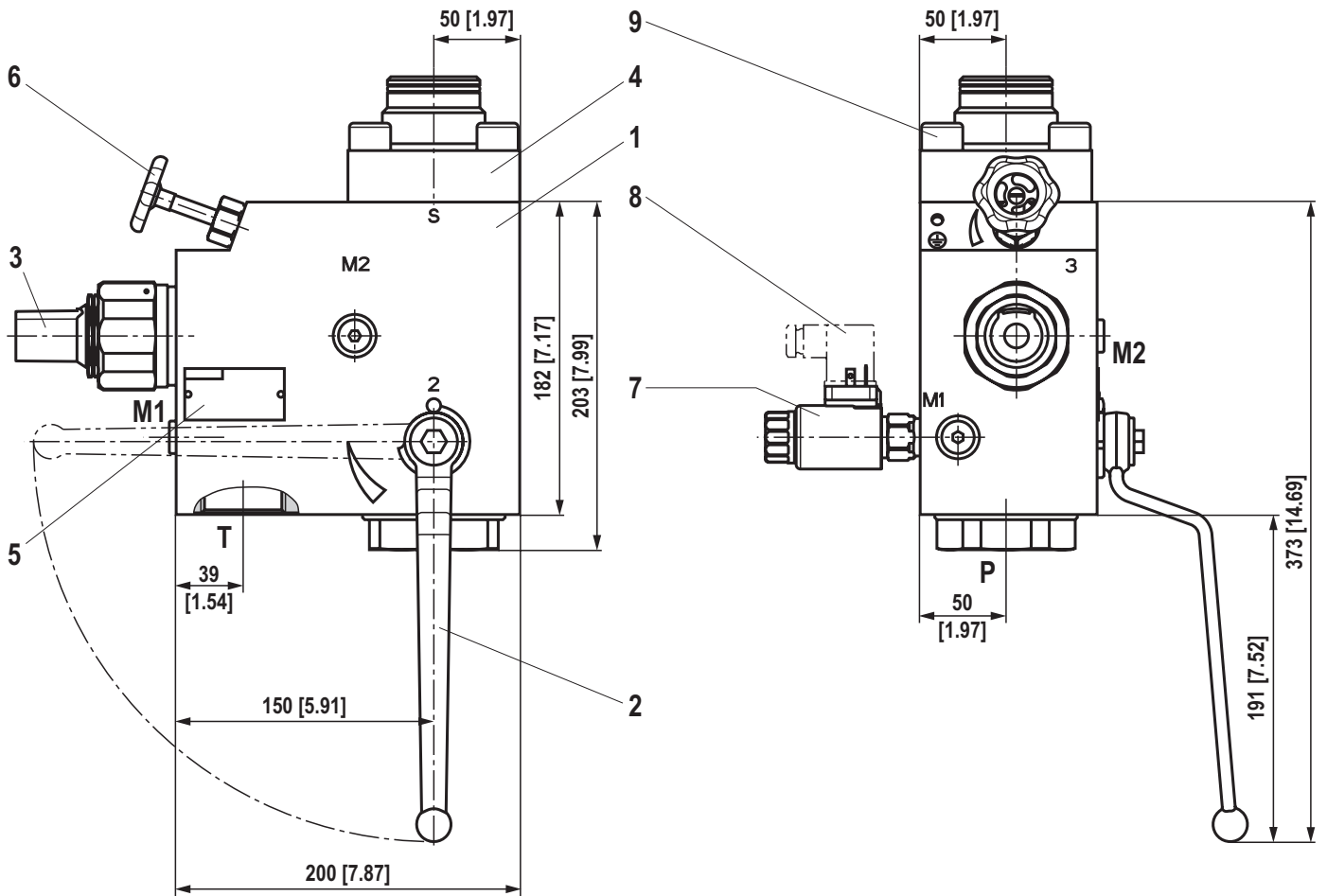

Connection thread		BSP	SAE
M1; M2	Measuring port	G1/4	7/6 - 20 UNF
P	Pump port	G1 1/2	1 7/8 - 12 UNF
T	Tank port	G1 1/2	1 7/8 - 12 UNF
S	Accumulator port (flange)	Page 16	Page 19

Item explanations see page 16

Characteristic curves for type-examination tested safety valves type DBDS can be found on page 8

Dimensions: Version "P30..." subplate mounting (DN30)
(dimension in mm [inch])

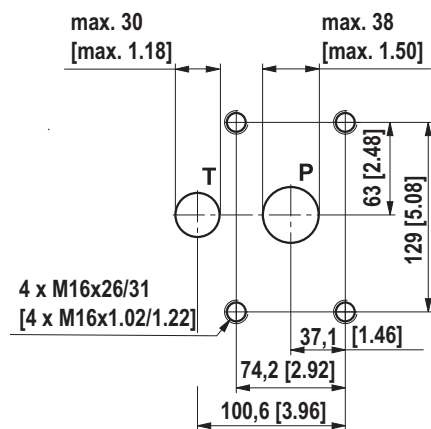
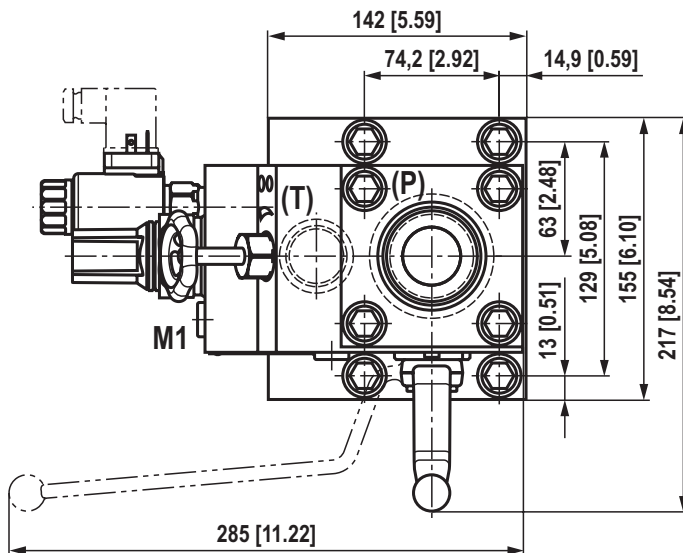
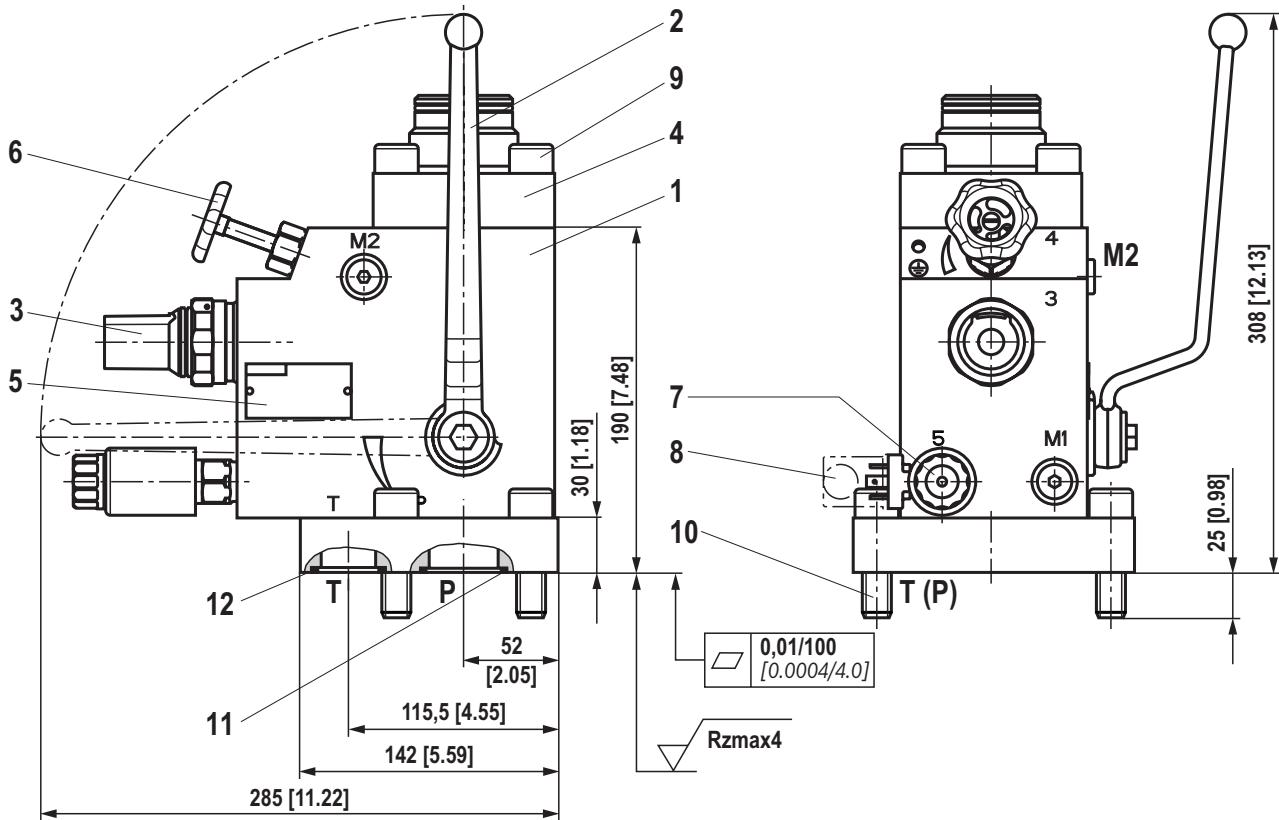

Connection thread	BSP	SAE
M1; M2	Measuring port	G1/4
S	Accumulator port (flange)	7/6 – 20 UNF

Item explanations see page 16

Characteristic curves for type-examination tested safety valves type DBDS can be found on page 8

Dimensions: Special versions "SO103" and "SO104" (for NG10 to NG30 only)

"SO103" shut-off device with two shut-off positions
(open or closed)

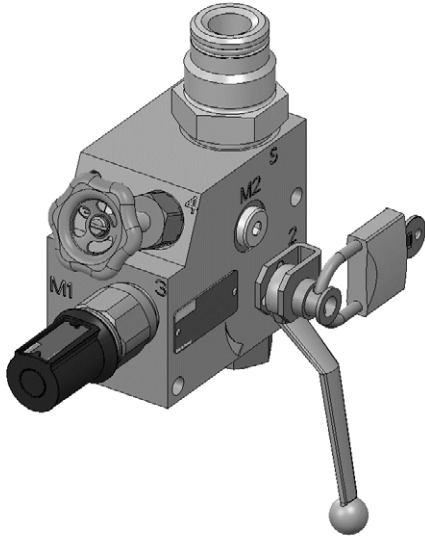

"SO104" shut-off device with one shut-off position
(closed)

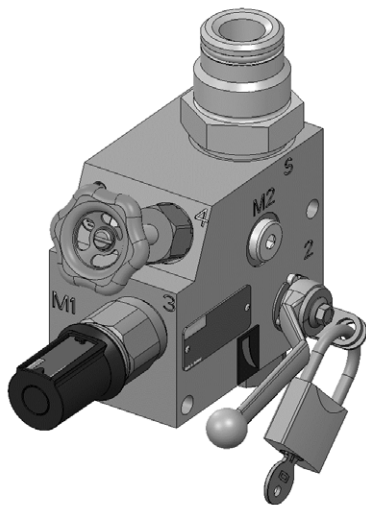

(padlock not included in the scope of delivery)

Dimensions

- 1 Block
- 2 System shut-off cock
- 3 Pressure relief valve, tightening torque see page 16
- 4 Accumulator adapter, see Accessories on page 17 ... 20
- 5 Name plate
- 6 Manual unloading
- 7 Electro-magnetic unloading, optional (only with design "E")
- 8 Mating connector, separate order, see page 16
- 9 Hexagon socket head cap screws
4 pieces ISO 4762 - M16 x 50 - 10.9
 Tightening torque $M_A = 250^{+10}$ Nm [184.07.4 ft-lbs]
- 10 Hexagon socket head cap screws
4 pieces ISO 4762 - M16 x 55 - 10.9
 Tightening torque $M_A = 250^{+10}$ Nm [184.07.4 ft-lbs]
- 11 R-ring 42.5 x 3.00 x 3.00 Shore 90
- 12 R-ring 34.52 x 3.53 x 3.53 Shore 90

Tightening torque: Pressure relief valve DBD

NG	Tightening torques M_A in Nm [ft-lbs] for screw-in cartridge valves ¹⁾	
	Pressure rating in bar [psi]	
	up to 200 [2900]	up to 400 [5800]
6	50±5 [37±3.7]	80±5 [59±4]
10	100±5 [74±3.5]	150±10 [110±3.5]
20	150±10 [111±7.5]	300±15 [221±11]
30	350±20 [258±19.5]	500±30 [369±22]

¹⁾ The tightening torques are guidelines with a friction coefficient $\mu_{\text{total}} = 0.12$ and when using a manual torque wrench.

Mating connectors according to DIN EN 175301-803

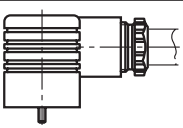
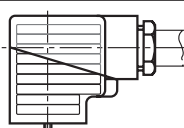
For details and more mating connectors see data sheet 08006					
Valve side	Color	Material number			
		Without circuitry	With indicator light 12 ... 240 V	With rectifier 12 ... 240 V	With indicator light and Zener diode suppression circuit 24 V
a	gray	R901017010	-	-	-
b	black	R901017011	-	-	-
a/b	black	-	R901017022	R901017025	R901017026

Accessories: Accumulator adapter BSP thread, maximum operating pressure 350 bar [5075 psi] (dimensions in mm [inch])

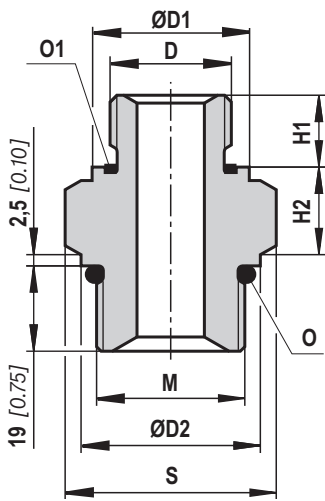

Fig. 1

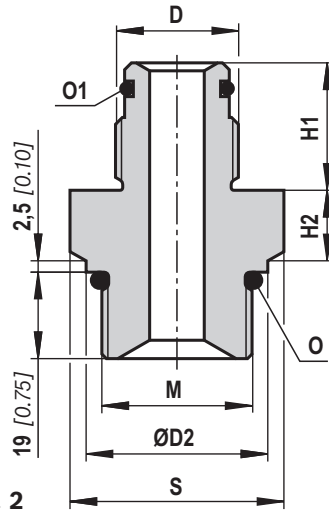

Fig. 2

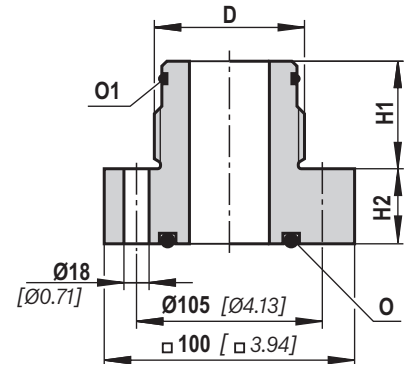

Fig. 3

Nominal Ø version	Accumulator type	Accumulator DN	Accumulator adapter	Fig.	D	ØD1	ØD2	H1	H2	M	O	O1	S										
ABZSS 08 10 20	Diaphragm type accumulator data sheet 50150	0.075	S30 ¹⁾ S104 ²⁾	1	G1/2A	26.9 [1.06]		14 [0.55]	19.5 [0.76] ¹⁾ 17.5 [0.68] ²⁾			Profile seal ring G1/2A according to DIN 3869	S30 ¹⁾ , S31 ¹⁾ , S108 ²⁾ , Wrench size 41 [1.61A/F], S104 ²⁾ Wrench size 36 [1.41A/F]										
		0.16						19.5 [0.76] ¹⁾ 18 [0.70] ²⁾															
		0.32																					
		0.5																					
		0.7																					
		1.0																					
	1.4																						
	2.0	S31 ¹⁾ S108 ²⁾	G3/4A	32 [1.26]	16 [0.63]																		
	ABZSS 30 P30	Bladder-type accumulator data sheet 50171	1.0	S10 ¹⁾ S105 ²⁾	2	G3/4A	-	39.9 [1.57] ¹⁾ 35.0 [1.37] ²⁾	28 [1.10]	15.5 [0.61]	33x2 ¹⁾ ; 20x1.5 ²⁾	29.7x2.8 ¹⁾ ; 24x2.0 ²⁾	18x2.5 [0.71x0.10]	wrench size 41 [1.61A/F] ¹⁾ Wrench size 36 [1.41A/F] ²⁾									
			2.5	S12 ¹⁾ S107 ²⁾					37 [1.46]	16.5 [0.65] ¹⁾ 17.5 [0.68] ²⁾					30x3 [1.18x0.12]	Wrench size 46 [1.81A/F]							
4.0																							
6.0																							
10.0			S13 ¹⁾ S109 ²⁾	G2A					-	43 [1.69]					20.5 [0.81] ¹⁾ 18.5 [0.73] ²⁾	48x3 [1.89x0.12]	Wrench size 65 [2.55A/F]						
20.0																							
35.0																							
50.0																							
ABZSS 30 P30				2.5					S307	3					G1 1/4A	-		37 [1.46]	30 [1.18]		56.52 x 5.33	48x3 [1.89x0.12]	-
				4.0																			
	6.0																						
	10.0	S309		G2A	-	43 [1.69]																	
20.0																							
35.0																							
50.0																							

 ▶ ¹⁾ applies to ABZSS10 and ABZSS20 only

²⁾ applies to ABZSS08 only

Accessories: ordering code accumulator adapter BSP thread

Version	ACCUMULATOR ADAPTER	Material no. FKM	ACCUMULATOR ADAPTER	Material no. NBR ²⁾
S10	S10V/G3/4-M33X2 *BG	R900545254	S10M/G3/4-M33X2 *BG	R900862699
S12	S12V/G1 1/4-M33X2 *BG	R900545255	S12M/G1 1/4-M33X2 *BG	R900862700
S13	S13V/G2-M33X2 *BG	R900545256	S13M/G2-M33X2 *BG	R900862701
S30	S30V/G1/2-M33X2 *BG	R900545252	S30M/G1/2-M33X2 *BG	R900862695
S31	S31V/G3/4-M33X2 *BG	R900545253	S31M/G3/4-M33X2 *BG	R900862697
S104	S104V/G1/2-M20X1.5* &	R901265402	S104M/G1/2-M20X1.5* &	R901265401
S105	S105V/G3/4-M20X1.5* &	R901265411	S105M/G3/4-M20X1.5* &	R901265407
S107	S107V/G11/4-M20X1.5*&	R901265412	S107M/G11/4-M20X1.5*&	R901265422
S108	S108V/G3/4-M20X1.5* &	R901265434	S108M/G3/4-M20X1.5* &	R901265425
S109	S109V/G2-M20X1,5* &	R901265408	S109M/G2-M20X1,5* &	R901265404
S307 ¹⁾	S307V/G 11/4-DN32 *BG	R900085303	S307M/G 11/4-DN32 *BG	R900067050
S309 ¹⁾	S309V/G2-DN32 *BG	R900545858	S309M/G2-DN32 *BG	R900862702

¹⁾ Scope of delivery includes 4 hexagon socket head cap screws ISO 4762-M16 x 50 - 10.9

²⁾ Special version

Accessories: Accumulator adapter SAE thread, maximum operating pressure 350 bar [5075 psi]
(dimensions in mm [inch])

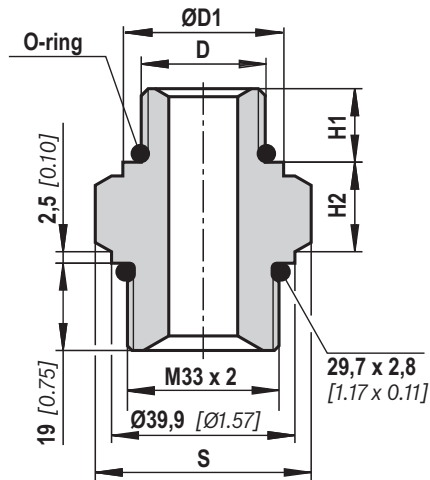

Fig. 1

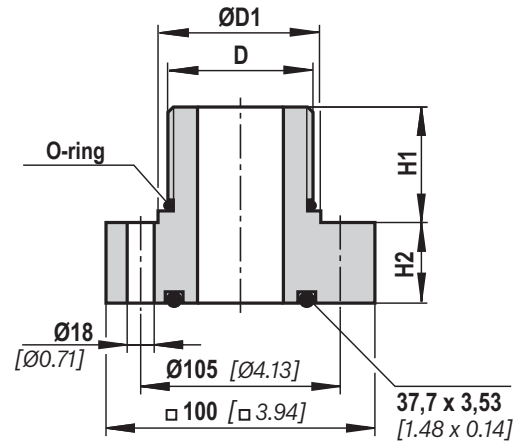

Fig. 2

Nominal Ø version	Accumulator type	Accumulator DN	Accumulator adapter	Fig.	S	H1	H2	D	ØD1	O-ring							
ABZSS 10 20	Diaphragm type accumulator data sheet 50150	0.075	S64	1	Wrench size 41 [1.61A/F]	11.4 [0.45]	18.1 [0.71]	3/4-16UNF-2A	23 [0.91]	16.36 x 2.21 [0.64 x 0.87]							
		0.16															
		0.32															
		0.5															
		0.7															
		1.0															
	1.4	S60	1	Wrench size 41 [1.61A/F]	15.2 [0.60]	18.3 [0.72]	1 1/16-12UN-2A	32 [1.26]	23.0 x 3.0 [0.91 x 0.12]								
	2.0																
	2.8																
	3.5																
Bladder-type accumulator data sheet 50171	1.0	S60	1	Wrench size 41 [1.61A/F]	15.2 [0.60]	18.3 [0.72]	1 1/16-12UN-2A	32 [1.26]	23.0 x 3.0 [0.91 x 0.12]								
										2.5	S62	Wrench size 65 [2.55A/F]	15.2 [0.60]	20.3 [0.80]	1 5/8-12UN-2A	48 [1.89]	38.0 x 3.0 [1.50 x 0.12]
	6.0																
	10.0	S620	2	-	15.2 [0.60]	32 [1.33]	1 5/8-12UN-2A	48 [1.89]	38.0 x 3.0 [1.50 x 0.12]								
										4.0	S630	15.2 [0.60]	32 [1.33]	1 7/8-12UN-2A	54 [2.13]	44.0 x 3.0 [1.73 x 0.12]	
																	6.0
										20.0							
35.0																	
										50.0							

Accessories: ordering code accumulator adapter SAE thread

Version	ACCUMULATOR ADAPTER	Material no. FKM	ACCUMULATOR ADAPTER	Material no. NBR ²⁾
S60	S60V/ 1 1/16-12UN-M33x2	R900618788	S60M/ 1 1/16-12UN-M33x2	R900618799
S62	S62V/ 1 5/8-12UN-M33x2	R900618800	S62M/ 1 5/8-12UN-M33x2	R900618801
S63	S63V/ 1 7/8-12UN-M33x2	R900618803	S63M/ 1 7/8-12UN-M33x2	R900618804
S64	S64V/ 3/4-16UNF-M33x2	R900618805	S64M/ 3/4-16UNF-M33x2	R900618806
S620 ¹⁾	S620V/ 1 5/8-12UN-DN32	R900618813	S620M/ 1 5/8-12UN-DN32	R900618814
S630 ¹⁾	S630V/ 1 7/8-12UN-DN32	R900618817	S630M/ 1 7/8-12UN-DN32	R900618815

¹⁾ Scope of delivery includes 4 hexagon socket head cap screws ISO 4762-M16 x 50 - 10.9

²⁾ Special version

Safety instructions: Type-examination tested safety valves type DBDS ¹⁾

- ▶ Before ordering a type-examination tested safety valve, ensure that for the desired **response pressure p** , the maximum admissible **flow q_{Vmax}** of the safety valve is larger than the maximum possible flow of the system/accumulator to be secured.
According to the Pressure Equipment Directive **2014/68/EU**, the increase in the system pressure due to the flow must not exceed 10% of the set response pressure (see component marking).
 - ▶ The maximum admissible flow q_{Vmax} stated in the component marking must not be exceeded.
 - ▶ Discharge lines of safety valves must end in a risk-free manner. An accumulation of fluids in the discharge system must **not** be possible (see data sheet AD2000 A2).
-  **It is imperative to observe the application notes!**
- ▶ In the plant, the response pressure specified in the component marking is set at a flow of 2 l/min [0.53 US gpm].
 - ▶ The maximum flow stated in the component marking applies for applications without counter pressure in the discharge line (port T).
- ▶ By removing the lead seal at the safety valve, the approval according to the Pressure Equipment Directive becomes void!
 - ▶ Basically, the requirements of the Pressure Equipment Directive and of data sheet AD 2000 A2 have to be observed!
 - ▶ It is recommended to secure type-examination tested safety valves against inadmissible disassembly by wiring and sealing them with the housing/block (bore available in the adjustment type).

 **Notice:**

The system pressure increases by the counter pressure in the discharge line (port T) due to the increasing flow. (Observe the data sheet AD 2000 A 2, point 6.3!)

To ensure that this increase in system pressure caused by the flow does not exceed 10% of the set response pressure, the admissible flow has to be reduced dependent on the counter pressure in the discharge line (port T) (see diagrams on page 22 ... 25).

¹⁾ Component series 1X according to the Pressure Equipment Directive 2014/68/EU

Characteristic curves: Counter pressure in the discharge line

In principle, the valve should be operated without counter pressure in the discharge line, if possible. In case of counter pressure in the discharge line, the maximum possible flow is reduced. There is a relationship between maximum counter pressure p_T in the discharge line and flow q_v , which can be seen from the following characteristic curve. Characteristic curves for intermediate values of the response pressure which are not listed must be determined by means of interpolation.

When the flow approaches zero, the maximum counter pressure p_T is in each case 10% of the response pressure. With increasing flow, the maximum counter pressure p_T decreases.

Interpolation of intermediate values from the diagram

1. At the axis p_T , mark 1/10 of the value of p_A .
2. Determine the next lower and the next higher characteristic curve for this point. The point marked at p_T divides the section between lower and higher characteristic curve on the p_T axis with a certain percentage.
3. At the q_{Vmax} axis, divide the section between next lower and next higher characteristic curve in the same percentage as the section at the p_T axis. From the zero position flow on the q_{Vmax} axis determined in that way, draw a straight line to the value on the p_T axis marked before.
4. Mark the system flow to be secured at the q_{Vmax} axis.
5. Read off the maximum counter pressure for this value using the line at the p_T axis drawn before.

Characteristic curves: Counter pressure in the discharge line – size 6

Diagram for determining the maximum counter pressure p_T in the discharge line at port T of the valve dependent on the flow q_{Vmax} for valves DBDS 6...1X/...E with different response pressures p_A .

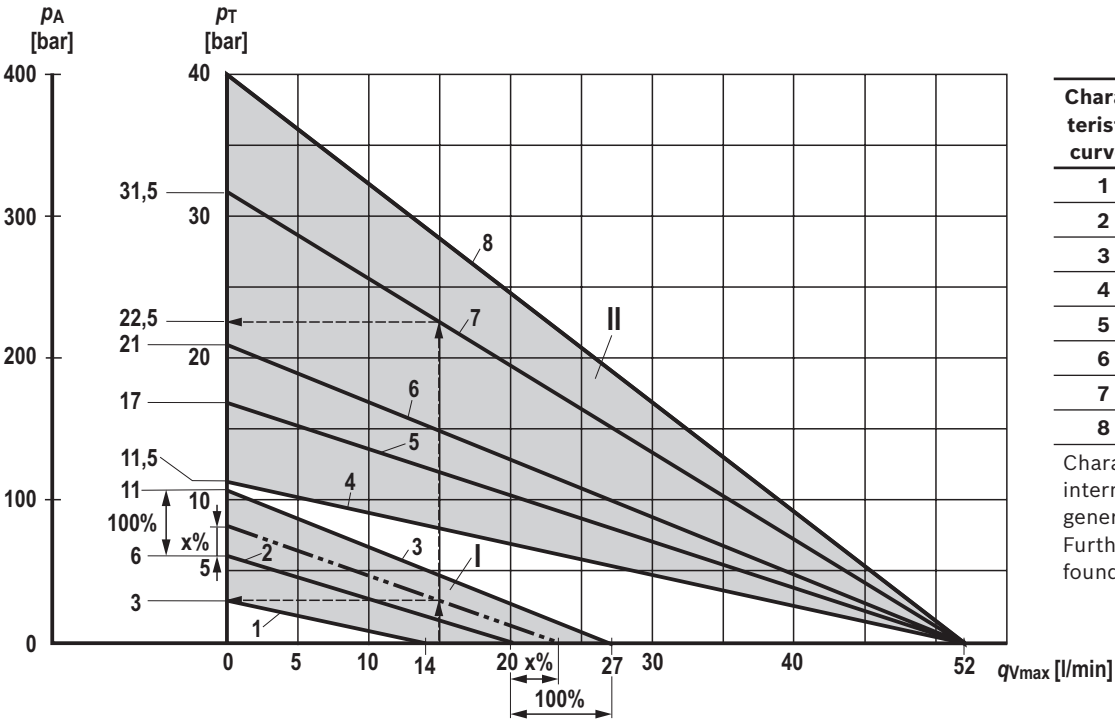

Characteristic curves	Response pressure p_A in bar [psi]
1	30 [435]
2	60 [870]
3	110 [1595]
4	115 [1668]
5	170 [2465]
6	210 [3046]
7	315 [4568]
8	400 [5800]

Characteristic curves for intermediate values can be generated by interpolation. Further explanations can be found on page 21.

- p_A Response pressure in bar
- p_T Maximum counter pressure in the discharge line (port T) in bar
- q_{Vmax} Maximum flow in l/min
- I** Interpolation area I, for valves with $p_A = 30 \dots 110$ bar and $q_{Vmax} = 14 \dots 27$ l/min
- II** Interpolation area II, for valves with $p_A = 115 \dots 400$ bar and $q_{Vmax} = 52$ l/min

Determination of the maximum counter pressure

Example 1 (with already existing characteristic curve):
 Flow of the system / accumulator to be secured: $q_{Vmax} = 15$ l/min
 Safety valve set to: $p_A = 315$ bar.
 Read off the maximum counter pressure p_T of approx. 22.5 bar from the diagram (see arrows, characteristic curve 7).



Example 2 (with interpolated characteristic curve):
 Flow of the system / accumulator to be secured: $q_{Vmax} = 15$ l/min
 Safety valve set to: $p_A = 80$ bar.
 Value to be marked at the axis referred to as p_T :
 $1/10 \times 80$ bar = 8 bar.
 Read off the maximum counter pressure p_T of approx. 3 bar from the diagram (see arrows, dashed characteristic curve).

Characteristic curves: Counter pressure in the discharge line – size 10

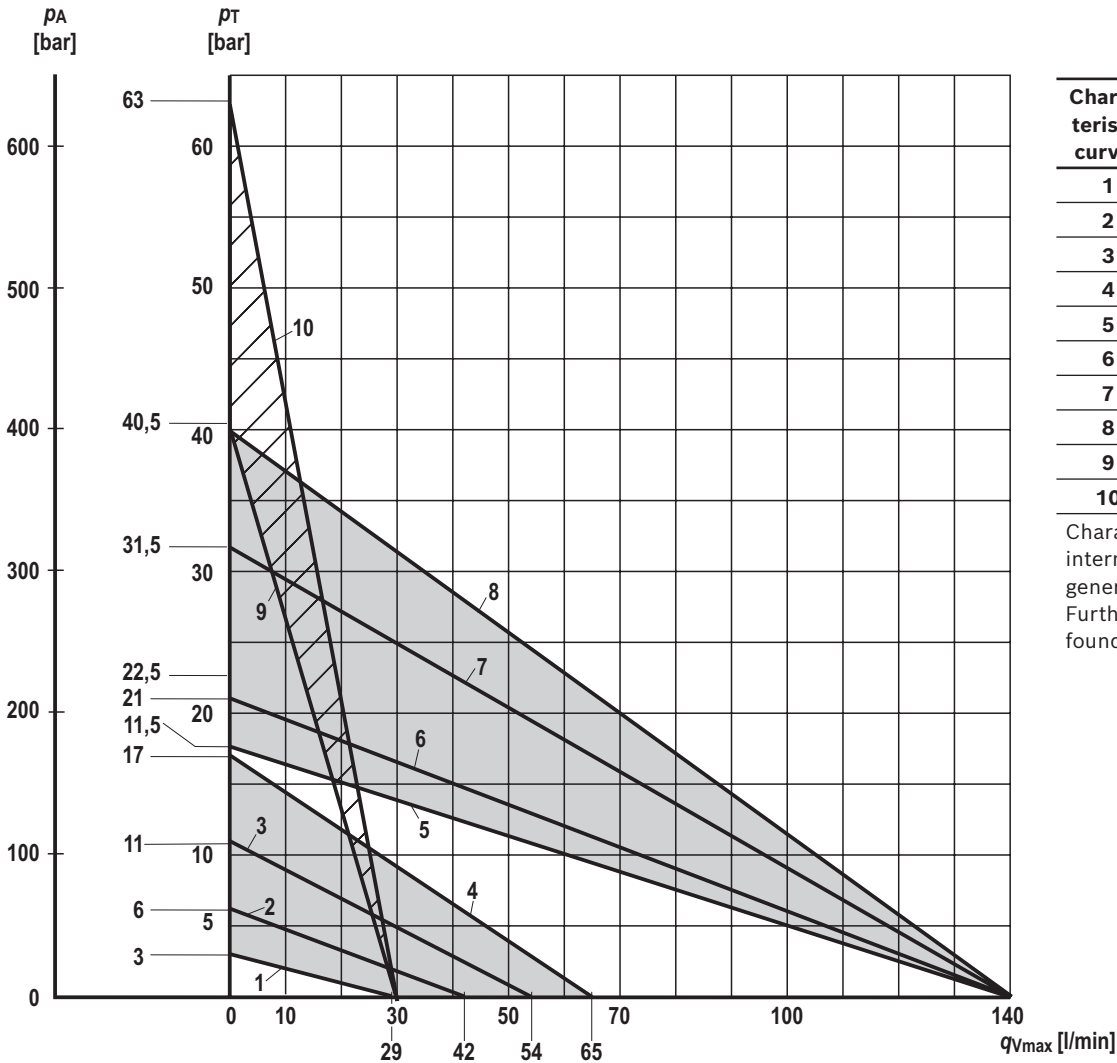
Diagram for determining the maximum counter pressure p_T in the discharge line at port T of the valve dependent on the flow q_{Vmax} for valves DBDS 10...1X/...E with different response pressures p_A .



Characteristic curves for intermediate values can be generated by interpolation. Further explanations can be found on page 21.

- p_A Response pressure in bar
- p_T Maximum counter pressure in the discharge line (port T) in bar
- q_{Vmax} Maximum flow in l/min
-  Interpolation areas
- 

Characteristic curves: Counter pressure in the discharge line – size 20

Diagram for determining the maximum admissible counter pressure p_T in the discharge line at port T of the valve dependent on the flow q_{Vmax} for valves DBDS 20...1X/...E with different response pressures p_A .

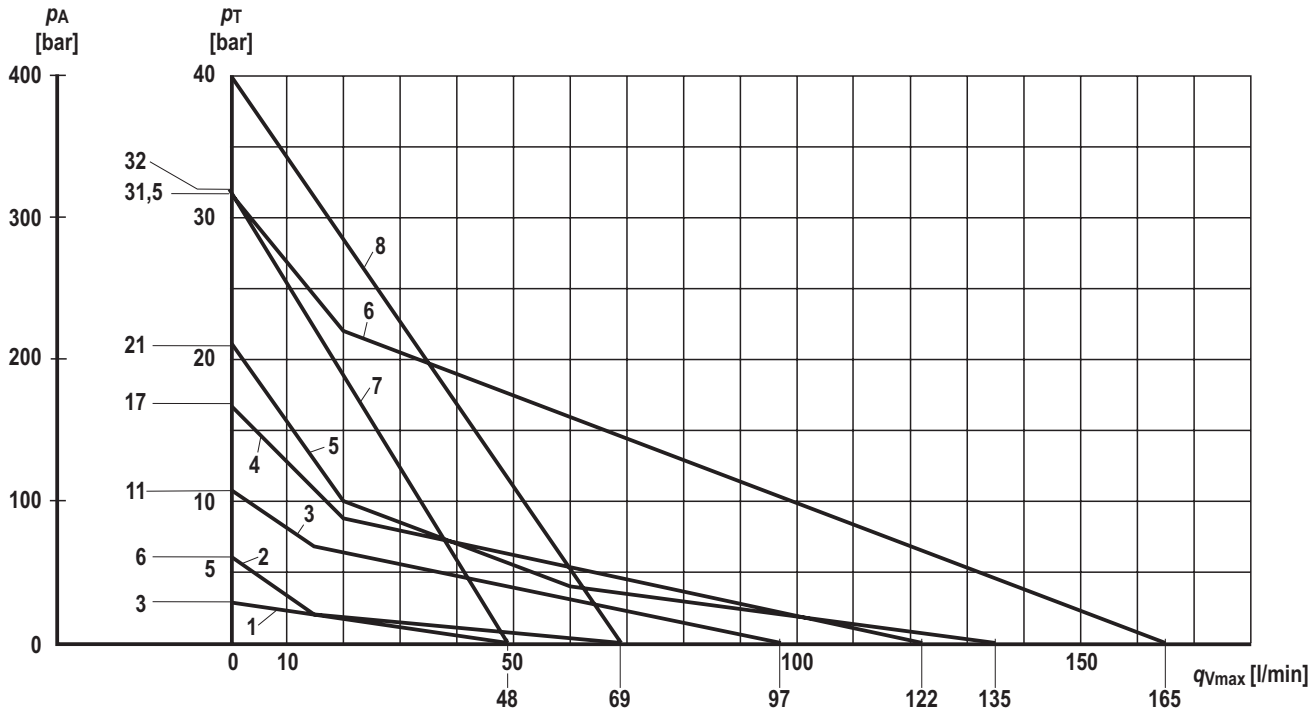

- p_A Response pressure in bar
 p_T Maximum counter pressure in the discharge line (port T) in bar
 q_{Vmax} Maximum flow in l/min

Characteristic curves	Response pressure p_A in bar [psi]
1	30 [435]
2	60 [870]
3	110 [1595]
4	170 [2465]
5	210 [3046]
6	315 [4568]
7	320 [4641]
8	400 [5800]

Characteristic curves for intermediate values can be generated by interpolation. Further explanations can be found on page [21](#).

Characteristic curves: Counter pressure in the discharge line – size 30

Diagram for determining the maximum counter pressure p_T in the discharge line at port T of the valve dependent on the flow q_{Vmax} for valves DBDS 30...1X/...E with different response pressures p_A .

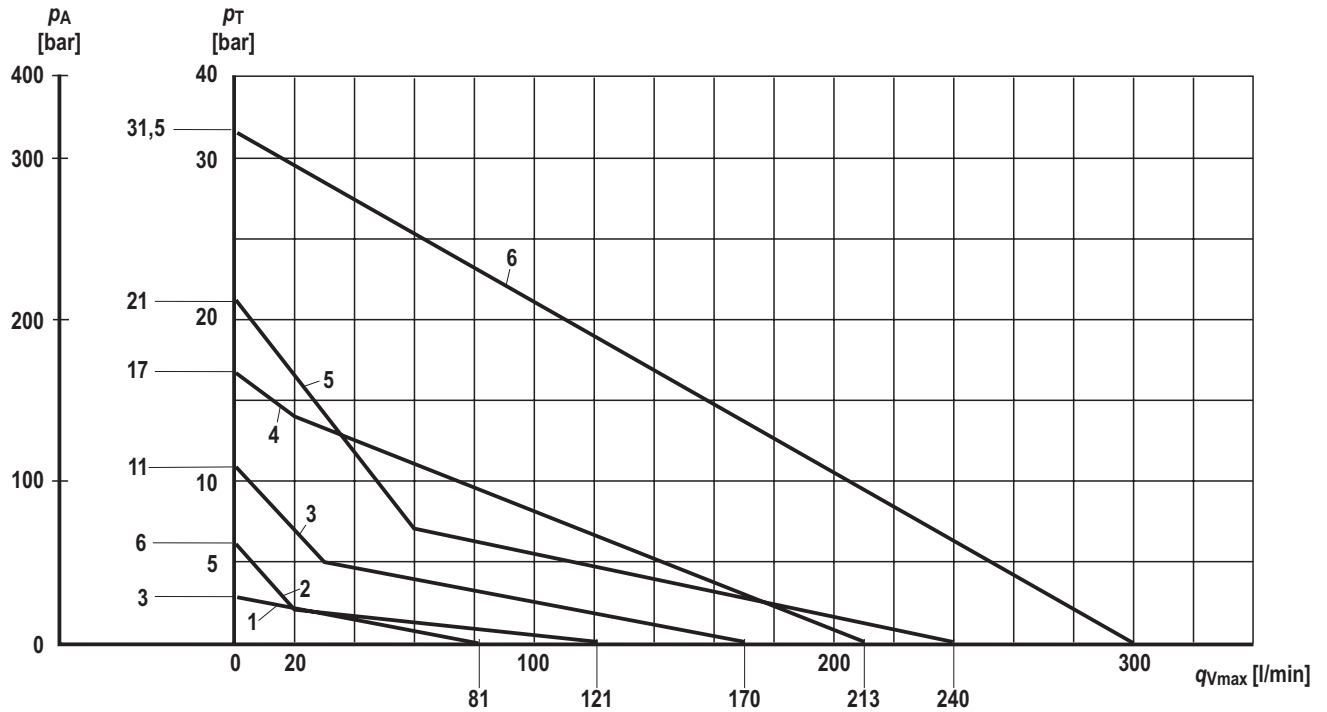

- p_A Response pressure in bar
 p_T Maximum counter pressure in the discharge line (port T) in bar
 q_{Vmax} Maximum flow in l/min

Characteristic curves	Response pressure p_A in bar [psi]
1	30 [435]
2	60 [870]
3	110 [1595]
4	170 [2465]
5	210 [3046]
6	315 [4568]

Characteristic curves for intermediate values can be generated by interpolation. Further explanations can be found on page [21](#).

Further information

- ▶ Accumulator shut-off block
 - ▶ 2/2 directional seat valve, direct operated with solenoid actuation
 - ▶ Pressure relief valve, direct operated
 - ▶ Hydraulic fluids on mineral oil basis
 - ▶ Environmentally compatible hydraulic fluids
 - ▶ Hexagon socket head cap screw, metric/UNC
 - ▶ Hydraulic valves for industrial applications
 - ▶ General product information on hydraulic products
 - ▶ Selection of the filters
 - ▶ Information on available spare parts
- Operating instructions 50129-B
Data sheet 18136-20
Data sheet 25402
Data sheet 90220
Data sheet 90221
Data sheet 08936
Operating instructions 07600-B
Data sheet 07008