

# Accumulator stations

## Type ABSBG

**RE 50135**

Edition: 2016-07

Replaces: 01.15



H7860\_d

- ▶ Component series 1X
- ▶ With diaphragm type accumulator according to data sheet 50150

### Features

- ▶ Accumulator station with shut-off block
- ▶ Diaphragm type accumulator
- ▶ Shut-off block with integrated shut-off valve, safety valve (type-examination tested) and drain valve
- ▶ Drain valve can be operated manually or electrically
- ▶ Glycerin-filled pressure gauge with red indication of the maximum admissible operating pressure on the dial
- ▶ Console for weld or screw connection
- ▶ Assembly prepared for external equipotential bonding

### Contents

Features	1
Ordering code	2, 3
Technical data	4, 5
Symbols	6
Spare parts and accessories	6
Standard program including preferred types	7, 8
Dimensions	9 ... 11
Commissioning, maintenance and operating instructions	12 ... 14

## Ordering code

01	02	03	04	05	06	07	08	09	10	11	12	13	14	15					
ABSBG	-	1X	/	M		N	-		/				G24	V	/	K	6		

01	Accumulator station (with diaphragm type accumulator according to directive 2014/68/EU)	ABSBG
02	Component series 10 to 19 (10 to 19: unchanged installation and connection dimensions)	1X

### Hydraulic accumulator

03	<b>Design</b>	
	Diaphragm type accumulator according to data sheet 50150	M

### Accumulator volume in liters (design)

04	<b>Diaphragm type accumulator</b>	
	0.7 liters	0.7
	1.4 liters	1.4
	2.0 liters	2.0
	2.8 liters	2.8
	3.5 liters	3.5

### Bladder/diaphragm material

05	e.g. Acrylonitrile-butadiene rubber (NBR)	N
----	---	---

### Country acceptance for hydraulic accumulator

06	Short symbol for country acceptance in Europe, Russia and China from the manufacturer's type key e.g.	
	Acceptance according to 2014/68/EU	CE
	Acceptance according to SELO (China)	88/CHN
	Acceptance according to GOST (Russia)	71/GOST
	Operating instructions	BA

### Accumulator shut-off block according to data sheet 50131

07	ABZSS 10 pressure relief valve 6E	10
----	-----------------------------------	----

### Unloading

08	manual and electro-magnetic	E
	manual	M

### Set pressure at the pressure relief valve

09	100 bar	100
	140 bar	140
	210 bar	210
	330 bar	330

### Voltage type

10	Direct voltage 24 V	G24
----	---------------------	-----

### Seal material

11	FKM	V
----	-----	---

### Mounting construction kit

12	Mounting using assembly kit K (console K)	K
----	---	---

### ABZMM pressure gauge according to data sheet 50205

13	DN63	6
----	------	---

**Ordering code**

01	02	03	04	05	06	07	08	09	10	11	12	13	14	15			
<b>ABSBG</b>	<b>-</b>	<b>1X</b>	<b>/</b>	<b>M</b>		<b>N</b>	<b>-</b>		<b>/</b>		<b>G24</b>	<b>V</b>	<b>/</b>	<b>K</b>	<b>6</b>		

**Pressure gauge scale**

14	bar/MPa	<b>M</b>
	bar/psi	<b>P</b>

**Accumulator manufacturer**

15	Bosch Rexroth	<b>DC</b>
	Parker Olaer	<b>OL</b>

**Order example:****ABSBG-1X/M0,7N-CE/10E140G24V/K6MDC**

**Technical data**

(For applications outside these parameters, please consult us!)

<b>Accumulator</b>		
Design		Diaphragm type accumulator
Installation position		Any, preferably with the fluid connection socket at the bottom
Ambient temperature range	°C	-15 ... +65
Line connection		Screw-in thread
Hydraulic fluid		Hydraulic oil according to DIN 51524; other liquids on request
Hydraulic fluid temperature range (others on request)	°C	-10 ... +80 (NBR diaphragm) -35 ... +80 (ECO diaphragm)
Acceptance specification for the accumulator	CE/BA	Acceptance according to 2014/68/EU or the operating instructions
	China	SELO
	Russia	GOST

<b>hydraulic, diaphragm type accumulator</b>								
Nominal volume	$V_{\text{rated}}$	l	0.7	1.4	2.0	2.8	3.5	
Effective gas volume	$V_{\text{eff}}$	l	0.75	1.4	1.95	2.7	3.5	
Maximum flow	$q_{\text{max}}$	l/min	40	40	60	60	60	
Maximum operating pressure	$p_{\text{max}}$	bar	350	350	350	350	350	
Max. adm. pressure fluctuation range	$\Delta p_{\text{dyn}}$	bar	130	130	130	130	130	

<b>pneumatic</b>		
Charging gas		Nitrogen, cleanliness class 4.0, N <sub>2</sub> = 99.99 vol. %
Gas filling pressure	$p_0$	bar 2 (Exception: diaphragm type accumulators with SELO acceptance are not prestressed)

## Technical data

(For applications outside these parameters, please consult us!)

Shut-off block		
Seal material		FKM seals (NBR seals on request)
Operating temperature range	°C	-15 ... +80
Maximum operating pressure	bar	350
Block material		Steel
Direct operated pressure relief valve		DBDS...K1X/...VB or DBDS...K1X/...E according to data sheet 25402
Cartridge seat valve		KSDER1PB/HN9V according to data sheet 18136-20
Protection class according to VDE 0470-1 – version "K4" (DIN EN 60529), DIN 40050-9		IP 65 with mating connector mounted and locked
Voltage type	V	24 (in case of electro-magnetic unloading "E")
Maximum admissible degree of contamination of the hydraulic fluid; Cleanliness class according to ISO 4406 (c)		Class 20/18/15

Hydraulic fluid	Classification	Suitable sealing materials	Standards
Mineral oils	HL, HLP	NBR, FKM	DIN 51524
Bio-degradable	– insoluble in water	HETG	VDMA 24568
		HEES	
	– soluble in water	HEPG	VDMA 24568

### Important information on hydraulic fluids!

- ▶ For more information and data on the use of other hydraulic fluids, please refer to data sheet 90220 or contact us!
- ▶ There may be limitations regarding the technical valve data (temperature, pressure range, life cycle, maintenance intervals, etc.)!
- ▶ The flash point of the hydraulic fluid used must be 40 K higher than the maximum solenoid surface temperature.

- ▶ **Flame-resistant – containing water:** The maximum pressure differential per control edge is 50 bar. Pressure pre-loading at the tank port > 20% of the pressure differential; otherwise, increased cavitation. The pressure peaks should not exceed the maximum operating pressures!
- ▶ **Bio-degradable:** When using bio-degradable hydraulic fluids that are zinc-solvent, zinc may accumulate in the fluid (700 mg zinc per pole tube).

Pressure gauge		
Size	bar	63
Pressure gauge		Glycerin
Double scale		bar/MPa

### Surface treatment

All steel components and components without protective coating are coated prior to installation (minimum corrosion protection time of 12 h in salt spray test). Then, the devices, components and the piping are installed. All components, assemblies, controls, pipes, fittings and standard parts keep the supplied surface protection and are not additionally coated. The corrosion protection is determined by the least protected element in the assembly.

## Symbols

### Accumulator station with manually operated drain valve

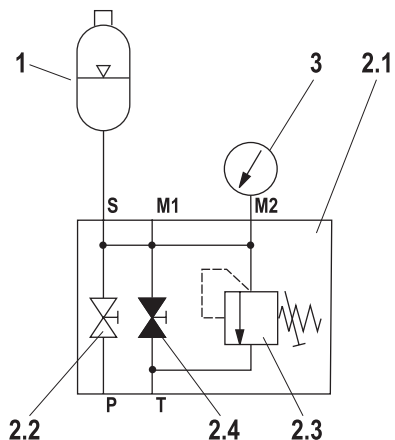

### Accumulator station with electro-mechanically operated drain valve

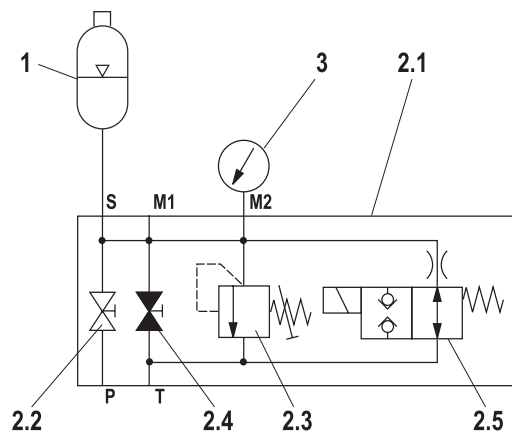

- 1** Hydraulic accumulator
- 2.1** Accumulator shut-off block with:
- 2.2** System shut-off cock
- 2.3** Pressure relief valve (type-examination tested)
- 2.4** Manual unloading
- 2.5** Electro-magnetic unloading (only version E)
- 3** Pressure gauge with red indication of the maximum admissible operating pressure

## Spare parts and accessories

- ▶ Diaphragm type accumulator with CE/BA acceptance according to data sheet 50150
- ▶ Shut-off block manual/electrical according to data sheet 50131
- ▶ Pressure gauge according to data sheet 50205
- ▶ Warning sign according to RNI 17506-001

Consoles contained in the assembly kit are intended for mounting by means of screws and nuts or for welding to suitable frames or design components.

## Standard program including preferred types: Accumulator stations

Accumulator type	Nominal volume in liters	Relief pressure in bar	Shut-off block DN	$\sim qv_{max}$ DBDS in l/min	CE/BA acceptances				Acceptance China		Acceptance Russia		
					Description	Material no.	Weight in kg	MKZ <sup>1)</sup>	Type of mounting	Material no.	MKZ <sup>1)</sup>	Material no.	MKZ <sup>1)</sup>
Diaphragm type accumulator	0.7	100	10	25	ABSBG-1X/M 0,7N-BA /10M100 V/K6M DC	R901301879	11	A3		R901302149	A3	R901302248	A3
		140	10	52	ABSBG-1X/M 0,7N-BA /10M140 V/K6M DC	R901301881	11	A3		R901302150	A3	R901302250	A3
		210	10	52	ABSBG-1X/M 0,7N-BA /10M210 V/K6M DC	R901280011	11	A3	K	R901302151	A3	R901302251	A3
	1.4	330	10	52	ABSBG-1X/M 0,7N-BA /10M330 V/K6M DC	R901280012	11	A3		R901302152	A3	R901302252	A3
		100	10	25	ABSBG-1X/M 1,4N-CE /10M100 V/K6M DC	R901301884	14	A3		R901302157	A3	R901302259	A3
		140	10	52	ABSBG-1X/M 1,4N-CE /10M140 V/K6M DC	R901280013	14	A2		R901290489	A3	R901302261	A3
	2	210	10	52	ABSBG-1X/M 1,4N-CE /10M210 V/K6M DC	R901301885	14	A3	K	R901302158	A3	R901302262	A3
		330	10	52	ABSBG-1X/M 1,4N-CE /10M330 V/K6M DC	R901280014	14	A3		R901302159	A3	R901302263	A3
		100	10	25	ABSBG-1X/M 2,0N-CE /10M100 V/K6M DC	R901280015	16	A3		R901302167	A3	R901302269	A3
	2.8	140	10	52	ABSBG-1X/M 2,0N-CE /10M140 V/K6M DC	R901301889	16	A3		R901302168	A3	R901302270	A3
		210	10	52	ABSBG-1X/M 2,0N-CE /10M210 V/K6M DC	R901301890	16	A3	K	R901302169	A3	R901302271	A3
		330	10	52	ABSBG-1X/M 2,0N-CE /10M330 V/K6M DC	R901280016	16	A3		R901302170	A3	R901302272	A3
3.5	100	10	25	ABSBG-1X/M 2,8N-CE /10M100 V/K6M DC	R901301893	21	A3		R901302175	A3	R901302277	A3	
	140	10	52	ABSBG-1X/M 2,8N-CE /10M140 V/K6M DC	R901301894	21	A3		R901302176	A3	R901302278	A3	
	210	10	52	ABSBG-1X/M 2,8N-CE /10M210 V/K6M DC	R901301895	21	A3	K	R901302177	A3	R901302279	A3	
3.5	330	10	52	ABSBG-1X/M 2,8N-CE /10M330 V/K6M DC	R901280017	21	A3		R901302178	A3	R901302281	A3	
	100	10	25	ABSBG-1X/M 3,5N-CE /10M100 V/K6M DC	R901301900	24	A3		R901302186	A3	R901302286	A3	
	140	10	52	ABSBG-1X/M 3,5N-CE /10M140 V/K6M DC	R901301901	24	A3		R901302187	A3	R901302287	A3	
3.5	210	10	52	ABSBG-1X/M 3,5N-CE /10M210 V/K6M DC	R901301902	24	A3	K	R901302188	A3	R901302289	A3	
	330	10	52	ABSBG-1X/M 3,5N-CE /10M330 V/K6M DC	R901280018	24	A3		R901302189	A3	R901302290	A3	

<sup>1)</sup> MKZ = material mark; A2 = preferred delivery range; A3 = standard delivery range

**Standard program including preferred types: Accumulator stations**

Standard program including preferred types with electrically operated drain valve (other versions on request)													
Accumulator type	Nominal volume in liters	Relief pressure in bar	Shut-off block DN	~ qv <sub>max</sub> DBDS in l/min	Description	CE/BA acceptances				Acceptance China		Acceptance Russia	
						Material no.	Weight in kg	MKZ 1)	Type of mounting	Material no.	MKZ 1)	Material no.	MKZ 1)
Diaphragm type accumulator	0.7	100	10	25	ABSBG-1X/M 0,7N-BA /10E100G 24V/K6M DC	R901301882	11	A3		R901302153	A3	R901302254	A3
		140	10	52	ABSBG-1X/M 0,7N-BA /10E140G 24V/K6M DC	R901301883	11	A3	K	R901302154	A3	R901302255	A3
		210	10	52	ABSBG-1X/M 0,7N-BA /10E210G 24V/K6M DC	R901280001	12	A3		R901302155	A3	R901302256	A3
		330	10	52	ABSBG-1X/M 0,7N-BA /10E330G 24V/K6M DC	R901280002	11	A3		R901302156	A3	R901302258	A3
	1.4	100	10	25	ABSBG-1X/M 1,4N-CE /10E100G 24V/K6M DC	R901301886	14	A3		R901302160	A3	R901302264	A3
		140	10	52	ABSBG-1X/M 1,4N-CE /10E140G 24V/K6M DC	R901280003	14	A2	K	R901302161	A3	R901302265	A3
		210	10	52	ABSBG-1X/M 1,4N-CE /10E210G 24V/K6M DC	R901301887	14	A3		R901302163	A3	R901302266	A3
		330	10	52	ABSBG-1X/M 1,4N-CE /10E330G 24V/K6M DC	R901280004	14	A3		R901302164	A3	R901302267	A3
	2.0	100	10	25	ABSBG-1X/M 2,0N-CE /10E100G 24V/K6M DC	R901280005	16	A3		R901302171	A3	R901302273	A3
		140	10	52	ABSBG-1X/M 2,0N-CE /10E140G 24V/K6M DC	R901301891	17	A3	K	R901302172	A3	R901302274	A3
		210	10	52	ABSBG-1X/M 2,0N-CE /10E210G 24V/K6M DC	R901301892	17	A3		R901302173	A3	R901302275	A3
		330	10	52	ABSBG-1X/M 2,0N-CE /10E330G 24V/K6M DC	R901280006	16	A3		R901302174	A3	R901302276	A3
2.8	100	10	25	ABSBG-1X/M 2,8N-CE /10E100G 24V/K6M DC	R901301896	22	A3		R901302181	A3	R901302282	A3	
	140	10	52	ABSBG-1X/M 2,8N-CE /10E140G 24V/K6M DC	R901301898	22	A3	K	R901302182	A3	R901302283	A3	
	210	10	52	ABSBG-1X/M 2,8N-CE /10E210G 24V/K6M DC	R901301899	22	A3		R901302183	A3	R901302284	A3	
	330	10	52	ABSBG-1X/M 2,8N-CE /10E330G 24V/K6M DC	R901280007	22	A3		R901302185	A3	R901302285	A3	
3.5	100	10	25	ABSBG-1X/M 3,5N-CE /10E100G 24V/K6M DC	R901301903	24	A3		R901302190	A3	R901302291	A3	
	140	10	52	ABSBG-1X/M 3,5N-CE /10E140G 24V/K6M DC	R901301904	24	A3	K	R901302191	A3	R901302292	A3	
	210	10	52	ABSBG-1X/M 3,5N-CE /10E210G 24V/K6M DC	R901301905	25	A3		R901302192	A3	R901302293	A3	
	330	10	52	ABSBG-1X/M 3,5N-CE /10E330G 24V/K6M DC	R901280008	24	A3		R901302193	A3	R901302294	A3	

1) MKZ = material mark; A2 = preferred delivery range; A3 = standard delivery range

**Dimensions:** Mounting with bracket K (dimensions in mm)

**Accumulator station with diaphragm type accumulator 0.7 to 3.5 liters**

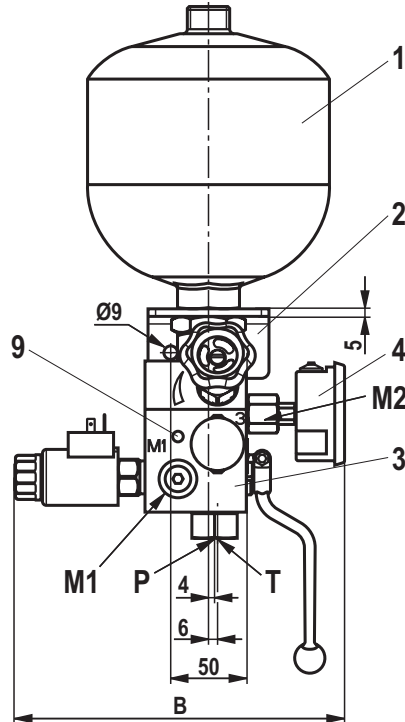
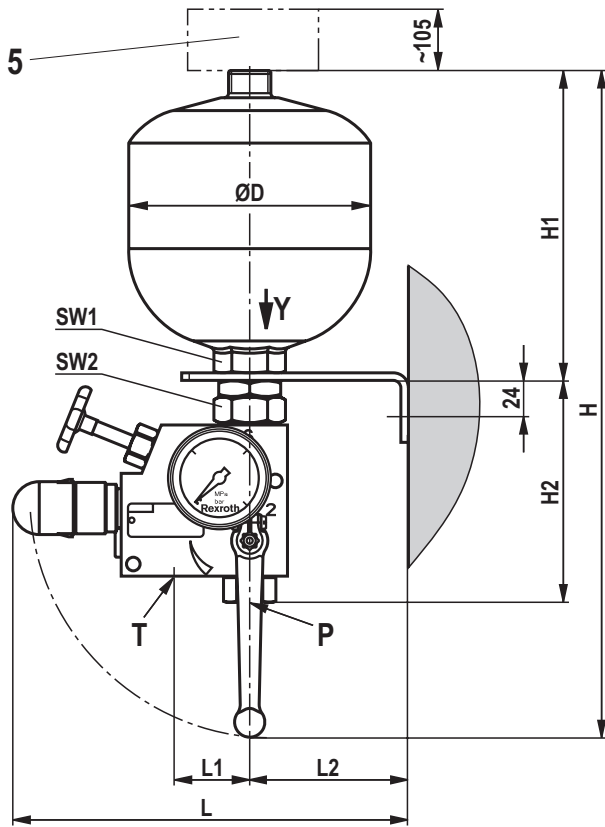

- 1 Hydraulic accumulator
- 2 Bracket
- 3 Shut-off block
- 4 Pressure gauge with red indication of the maximum admissible operating pressure
- 5 Space required for filling device
- 6 Name plate of the accumulator station
- 7 Functional sign (loose)
- 8 Warning sign (loose)
- 9 Threaded connection M8 for equipotential bonding

Connection designations:

- M1** Measuring port G 1/4
- M2** Pressure gauge connection G 1/4
- P** Pump connection G 1/2
- T** Tank port G 3/8

The gas filling pressure of the accumulators upon delivery is 2 bar.

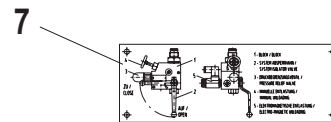
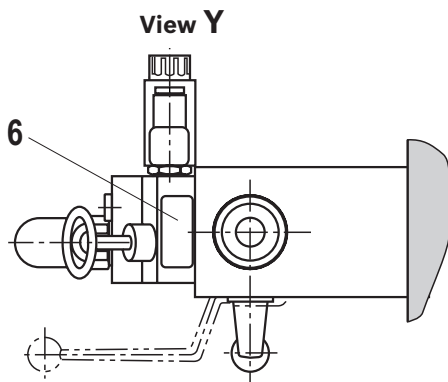

ABSBG-... assembly kit	ØD	H	H1	H2	L	L1	L2	B	SW1	SW2
M0,7/10	128.5	402.5	171	132.5	262	50	105	217	SW 41	SW 41
M1,4/10	156	427.5	196						SW 50	SW 60
M2,0/10		512.5	281						SW 50	
M2,8/10	180	501.5	270						SW 55	
M3,5/10		541.5	310							

## Commissioning, maintenance and operating instructions

### General Information

- ▶ Observe the documentation for the machinery.
- ▶ Also observe the documentation pertaining to the other components, assemblies and partly completed machinery, which form part of the complete machinery.
- ▶ Observe the generally applicable, legal or otherwise binding European and national regulations as well as the relevant legislation for your country pertaining to the prevention of accidents and protection of the environment.
- ▶ Operating instructions according to data sheet of the accumulator
- ▶ Depending on the country of installation, national pressure vessel regulations need to be complied with.
- ▶ In the standard, the country acceptance is effected according to BA, CE as well as for China and Russia Other acceptances on request.
- ▶ Please indicate the country of installation in the order.
- ▶ Keep all documents included in the delivery in a safe place; they will be required by the expert in recurring tests.
- ▶ The machine end-user will have sole responsibility for complying with existing provisions.
- ▶ The accumulator stations in this edition are assemblies in the sense of directive 2014/68/EU, article 2, section 6 (Pressure Equipment Directive). However, they are not intended for exclusive commissioning. They are installed as a component of a larger assembly or system.
- ▶ The accumulator stations described here contain the entire equipment which is required for safety reasons according to DIN EN ISO 4413.
- ▶ The accumulator stations must not be modified; otherwise, the operating license according to directive 2014/68/EU will be lost and the dealer and/or manufacturer warranty will be forfeited.
- ▶ The accumulator stations may only be operated within the admissible limit values.
- ▶ Repairs may only be carried out by the manufacturer or their authorized dealers and agencies. Repairs performed by third parties invalidate the approval and release the manufacturer from all claims resulting from an unauthorized intervention.
- ▶ Assembly and maintenance must be implemented by authorized, instructed persons only.

## Commissioning, maintenance and operating instructions

- ▶ The accumulator stations are provided with signs: **1**
  - 1. Name plate** specifying the pressure rating, identifies the device
  - 2. Functional sign**, identifies the components and elementary lever positions
  - 3. Warning sign**, has to be clearly visible and attached at the device or next to it.

Usually, the warning sign is in the languages according to the country acceptance. Other languages on request.

For hydraulic systems with one or several hydraulic accumulators whose warning signs are not visible after installation into the machine, an additional warning sign has to be attached visibly to the system, stating:

**"CAUTION - system contains hydraulic accumulators."**

The circuit diagram has to contain the same notice. With mounting "B" and "K", the warning signs and functional signs are supplied loosely and must be attached to or close to the accumulator station in a clearly visible position. The attachment of the signs must already be considered in the design.

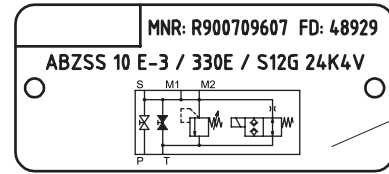

Example

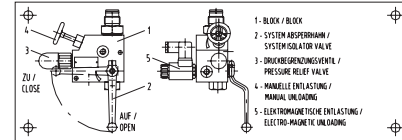



<b>Vorsicht Druckbehälter</b>	
Druckentlastung vor Beginn der Demontage	
Gasvorfülldruck: _____ bar	
Füllen nur mit Stickstoff _____ bar	
<p><b>Attention: Pressure vessel</b> Discharge pressure prior to disassembly Gas pre - charge pressure: _____ bar Only fill with nitrogen.</p>	<p><b>Attenzione! Serbatoio in pressione</b> Scaricare la pressione prima di iniziare lo smontaggio Pressione di precarica del gas: _____ bar Riempiere solo con azoto.</p>
<p><b>Attention: réservoir sous pression</b> Déchargement avant le démontage Pression de précharge de gaz: _____ bars Seulement remplissage d'azote.</p>	<p><b>Atención. Recipiente a presión</b> Descargar la presión antes del desmontaje Presión precarga gas: _____ bar Llenar sólo con nitrógeno.</p>
<p><b>Varning: Tryckbehållare</b> Före demontering måste anläggningen göras trycklös Gas - försladdningstryck: _____ bar Fylls enbart med kväve.</p>	<p><b>Cuidado: Reservatório sob pressão</b> Descarga antes da desmontagem Pressão de pré - carga de gás: _____ bar Encher só com nitrogênio.</p>
<p><b>ADVARSEL TRYKBEHOLDER</b> TRYKFLASTES FOR FÆRDYNDELSE AF DEMONTAGE GAS - FØRSLADDNINGSPRES MA KUN FYLDES MED KVÆLSTOF _____ BAR</p>	<p><b>Voorzichtig drukvat</b> Druk ontlasten voor aanvang demontage Gas - voorvuldruk: _____ bar Alleen met stikstof vullen.</p>
<p><b>ADVARSEL TRYKBEHOLDER</b> Trykk skal avlastes før demontering Gas - Førlastetrykk _____ bar Ma kun fylles med nitrogen.</p>	<p><b>HUOMIOI PAINEASTIA</b> PAINENPURKU ENEN KÖRÄLÄISTÖIDEN ALOITTAMISTA KAASUN ESITÄHTTÖPAINA TÄTTÖ SALLITTU VAIN TYPIKKAASULLA _____ BAR</p>
<p><b>ΠΡΟΣΟΧΗ ΔΕΞΙΩ ΤΥΠΟ ΠΙΣΤΙΣ</b> ΕΠΙΣΤΡΕΦΕΙ ΜΕΤΑ ΤΗΝ ΑΔΕΛΦΟΤΗΤΑ ΕΠΙ ΤΗΣ ΣΥΜΒΟΛΗΣ ΕΠΙΣΤΡΕΦΕΙ ΣΤΗΝ ΑΔΕΛΦΟΤΗΤΑ ΕΠΙ ΤΗΣ ΣΥΜΒΟΛΗΣ ΕΠΙΣΤΡΕΦΕΙ ΜΟΝΟ ΜΕ ΑΖΩΤΟ _____ BAR</p>	<p><b>Vigyazat, nyomastartaly</b> Szétcszerelés előtt nyomásmérsztereni kell Gáz - előtöltőnyomás: Csak nitrogémmel tölthető fel _____ bar</p>
<p><b>Uwaga zbiornik ciśnieniowy</b> Przed demontażem należy rozładować gazem Napełniać tylko azotem _____ bar</p>	<p><b>Pozor tlakova nadoba</b> Pred demontaz odstavkovat Prisic tlak plynu. Pinit jen dusikom _____ bar</p>

MNR : R900751679

## Commissioning, maintenance and operating instructions

### Commissioning - Operating instructions according to data sheet of the accumulator!

	<p><b>DANGER</b> Do not charge hydraulic accumulators with oxygen or air. Explosion hazard!</p> <ul style="list-style-type: none"> <li>▶ Prior to the initial commissioning, the hydraulic accumulator must be filled with nitrogen of class 4.0, pure (N<sub>2</sub> content 99.99 vol. %). The preset gas pressure necessary for the operation is indicated in the circuit diagrams and operating instructions.</li> <li>▶ Only use suitable filling and testing devices for filling. We recommend using the charging and test devices by Bosch Rexroth according to data sheet 50150.</li> </ul>
	<p><b>WARNING</b></p> <ul style="list-style-type: none"> <li>▶ Risk of injury caused by improper assembly.</li> <li>▶ Hydraulic accumulators are energy stores. They may supply the energy for uncontrolled movements to actuators.</li> <li>▶ Before beginning any repairs, the system must be depressurized on the oil and gas side and protected against unauthorized re-start.</li> <li>▶ Do not carry out welding and soldering works or any mechanical processing at the accumulator tank! Any kind of work at the product invalidates the declaration of conformity and the operating license!             <ul style="list-style-type: none"> <li>– Explosion hazard due to welding and soldering works!</li> <li>– Danger of bursting during and after mechanical processing.</li> </ul> </li> <li>▶ A warning sign is enclosed to the accumulator station. It is to be attached to or close to the accumulator station in a clearly visible position.</li> </ul>

### Maintenance

	<p><b>Attention</b></p> <ul style="list-style-type: none"> <li>▶ In case of damage at the accumulator bladder or diaphragm, the accumulator will lose its function immediately.</li> <li>▶ Loss of the initial gas tension will lead to damage at the accumulator bladder or the accumulator diaphragm if operation of the system is continued nevertheless.</li> <li>▶ Check the initial gas tension in regular intervals.</li> </ul>
--	--

### Legal provisions

- ▶ Hydraulic accumulators are pressure vessels and subject to the application national provisions and/or regulations valid at the place of installation.
- ▶ In Germany, the Ordinance on Industrial Safety and Health (BetrSichV) applies.
- ▶ As a standard, country acceptances are effected according to BA, CE as well as for China and Russia. Other acceptances on request.
- ▶ Special regulations are to be observed in shipbuilding, aircraft construction, mining, etc.
- ▶ Design, production and testing are effected according to the data sheets according to AD 2000. Installation, equipment and operation are controlled by the "Technical rules Pressure vessels" (TRB).

### Note pursuant to the EC Machinery Directive 2006/42/EC, according to annex II part 1, section A, manufacturer's declaration:

- ▶ The assemblies were manufactured in accordance with the harmonized standards DIN EN ISO 4413, DIN EN ISO 12100, EN 983, and EN 60204-1.
- ▶ Commissioning is prohibited until it was confirmed that the machine into which the assemblies are to be integrated complies with the regulations laid down in the EC Directives.