

Diaphragm accumulator

Type HAD



HAD0,7-210_d

- ▶ Component series 1X and 2X
- ▶ Nominal volume 0.075 ... 3.5 liters
- ▶ Maximum operating pressure 350 bar

CE

EAC

Features

- ▶ Hydro-pneumatic accumulator for use in mobile machines and stationary machinery and systems
- ▶ Use:
 - Energy storage in intermittent operation systems
 - Energy reserve for emergencies
 - Impact and vibration absorption
 - Volume compensation in case of pressure and temperature change
- ▶ Approval:
 - according to PED 2014/68/EU
 - according to TR CU 032/2013

Contents

Features	1
Ordering code	2, 3
Function, section	4
Technical data	5
Application, mode of operation	6
Calculation	6, 7
Characteristic curves	8, 9
Dimensions	10 ... 13
Accessories	14 ... 18
Important notes, safety equipment	19
Commissioning, further information	20

Ordering code

01	02	03	04	05	06	07	08	09	10	11	12	13	14
HAD		-	-	/			-		1	1	1	-	-

01	Diaphragm accumulator	HAD
----	-----------------------	-----

Nominal volume

02		0.075	0.16	0.35	0.5	0.6	0.7	1.0	1.4	2.0	2.8	3.5	
----	--	-------	------	------	-----	-----	-----	-----	-----	-----	-----	-----	--

Maximum operating pressure

03	55 bar												o	55	
	70 bar											o	70		
	100 bar								o				o	100	
	140 bar									o					140
	160 bar				o	o								160	
	180 bar							o							180
	200 bar									o					200
	210 bar				o				o						210
	250 bar	•	•	•	•	•	•	•	•	•	•	•	•	250	
	330 bar						•							330	
350 bar									o	o	o	o	o	350	

Component series

04	Component series 10 ... 19 (only with these nominal volume/ pressure combinations)	250	250	160 210 250	160	330	100 180 210 250	200 250	140 250	100 250	70		1X
	Component series 20 ... 29 (only with these nominal volume/ pressure combinations)				250		350		350	350	250 350	55 250	2X

Preload pressure

05	0 bar	•	•	•	•	•	•	•	•	•	•	•	0
	1 ... 250 bar	o	o	o	o	o	o	o	o	o	o	o	1 ... 250

Port size for hydraulic fluid ¹⁾

06	M14x1.5	o											Z04	
	M18x1.5		o	o	o		o		o				Z06	
	M22x1.5								o	o	o	o		Z08
	G1/2	•	•	•	•	•	•	•	•	o	o		G04	
	G3/4										•	•	•	G05

Type of mounting for hydraulic fluid ¹⁾

07	Mounting cavity		o	o	o		o						A	
	Mounting cavity with external hexagon	•	•	•	•	•	•	•	•	•	•	•	C	
	Screw-in stud	o	o										F	
	Screw-in stud M33x1.5 with internal thread							o	o	o				E
	Screw-in stud M45x1.5 with internal thread										o	o	o	E5

•	Preferred program
o	Delivery range
	On request

¹⁾ Other ports upon request

Ordering code

01	02	03	04	05	06	07	08	09	10	11	12	13	14
HAD		-	-	/			-		1	1	1	-	-

Nominal volume

02		0.075	0.16	0.35	0.5	0.6	0.7	1.0	1.4	2.0	2.8	3.5	
----	--	-------	------	------	-----	-----	-----	-----	-----	-----	-----	-----	--

Gas port form ¹⁾

08	Standard	•	•	•	•	•	•	•	•	•	•	•	1
----	----------	---	---	---	---	---	---	---	---	---	---	---	---

Diaphragm material

09	NBR	•	•	•	•	•	•	•	•	•	•	•	N
	ECO		o	o	o		o	o	o		o	o	E
	FKM						o						F

Tank material

10	Steel	•	•	•	•	•	•	•	•	•	•	•	1
----	-------	---	---	---	---	---	---	---	---	---	---	---	---

Surface of the tank inside

11	Steel	•	•	•	•	•	•	•	•	•	•	•	1
----	-------	---	---	---	---	---	---	---	---	---	---	---	---

Surface of the connection side

12	Steel	•	•	•	•	•	•	•	•	•	•	•	1
----	-------	---	---	---	---	---	---	---	---	---	---	---	---

Approval ²⁾

13	Operating instructions	EU	•	•	•	•	•	•	•				BA
	PED 2014/68/EU	EU							•	•	•	•	CE
	TR CU 032/2013	EU + Eurasian customs union							o	o	o	o	CE+ EAC

Additional details

14	Further details in the plain text, e.g. special versions												*
----	---	--	--	--	--	--	--	--	--	--	--	--	---

•	Preferred program
o	Delivery range
	On request

¹⁾ Other ports upon request²⁾ Further approvals upon request

Function, section

General

One of the main tasks of hydro-pneumatic accumulators is e.g. to accept certain volumes of pressurized liquids of hydro-pneumatic installations and to return them to the system if required.

As the liquid is pressurized, the hydro-pneumatic accumulators are treated like pressure vessel and must be designed for the max. operating over-pressure considering the acceptance standards of the country of installation.

In most hydro-pneumatic systems, hydro-pneumatic accumulators with separator element are used.

The difference between bladder, piston and diaphragm accumulators lies in the type of separator element.

Hydro-pneumatic accumulators essentially consist of a fluid section and a gas section with a gas-tight separator element. The fluid section has a connection to the hydraulic circuit. During the pressure increase, the gas is compressed and liquid accepted in the hydro-pneumatic accumulator. When the pressure decreases, the compressed gas expands and displaces the accumulated fluid into the circuit.

Diaphragm accumulator

Diaphragm accumulators consist of a pressure-resistant steel vessel (1) which most commonly has a spherical to cylindrical form. Inside the accumulator, there is the separator element, namely a diaphragm (2) made of an elastic, flexible material (elastomer) with the closing button (3) and the plug screw (4). They correspond to Pressure Equipment Directive 2014/68/EU.

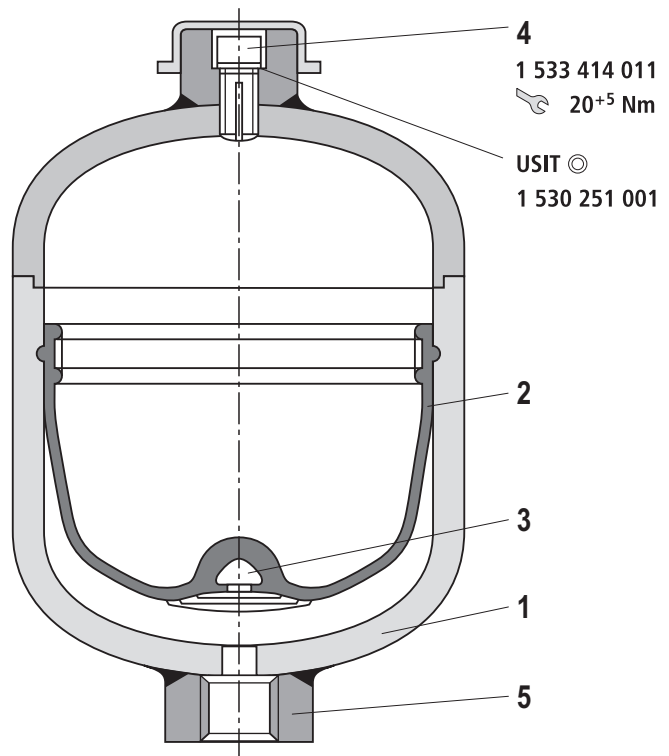

- 1 Tank
- 2 Diaphragm
- 3 Closing button
- 4 Plug screw (gas filling screw)
- 5 Fluid connection

Symbol



Technical data

(For applications outside these values, please consult us!)

General	
Design	Diaphragm accumulator, welded
Installation position	Any, preferably with the fluid connection socket at the bottom
Type of mounting	With clamps or via stud end connectors
Line connection	Screw-in thread
Surface	Painted, color glossy black

Hydraulic															
Nominal volume V_{nom}	l	0.075	0.16	0.35	0.5	0.6	0.7	1.0	1.4	2.0	2.8	3.5			
Effective gas volume V_{eff}	l	0.075	0.16	0.32	0.48	0.6	0.75	1.0	1.4	1.95	2.7	3.5			
Maximum admissible flow q_{max}	l/min	10		40						60					
Maximum admissible operating pressure p_{max}	bar											55 [45]			
												70 [50]			
								100 [50]			100 [50]				
										140 [80]					
						160 [90]	160 [90]								
								180 [93]							
		[Durable within pressure fluctuation range] $[\Delta p_{dyn} = p_2 - p_1]$	[bar]								200 [115]				
							210 [120]			210 [93]					
				250 [140]	250 [140]	250 [120]	250 [90]			250 [140]	250 [140]	250 [140]	250 [140]	250 [140]	250 [140]
									330 [140]						
						350 [140]			350 [140]	350 [140]	350 [140]	350 [140]			

Hydraulic fluid	Classification	Material	Standards	Data sheet	
Mineral oils	HLP, HLPD, HVLP, HVLPD	NBR, ECO	DIN 51524	90220	
Special fluids	▶ containing water, flame-resistant	HETG, HEES, HEPG	FKM, NBR	ISO 15380	90223
	▶ environmentally compatible	HFC	NBR	ISO 12922	90221
	▶ water-free, flame-resistant	HFDU, HFDR	FKM	ISO 12922	90222
	▶ containing water, flame-resistant	HFC	NBR	ISO 12922	90223

Pneumatic	
Charging gas	Nitrogen, at least cleanliness class 4.0, $N_2 = 99.99 \text{ vol.}\%$
Gas filling pressure (at 20 °C room temperature)	p_0 bar see preferred types page 12 , page 13

Further information on the hydraulic fluids:	
Temperature range (others on request)	°C NBR: -15 ... +80 ¹⁾ ECO: -35 ... +80 ²⁾ FKM: -10 ... +80 ³⁾
Maximum admissible degree of contamination of the hydraulic fluid, cleanliness class according to ISO 4406 (c)	Class 20/18/15

1) Acrylonitrile-butadiene rubber

2) Epichlorhydrin rubber

3) Fluorocarbon rubber

Application, mode of operation

Applications

Various applications exist for hydro-pneumatic accumulators:

- ▶ Energy storage in order to save pump drive power in intermittent operation systems.
- ▶ Energy reserve for emergencies, e.g. upon failure of the hydraulic pump.
- ▶ Compensation of leakage losses.
- ▶ Impact and vibration absorption in case of periodic vibrations.
- ▶ Volume compensation in case of pressure and temperature changes.
- ▶ Suspension element for vehicles.
- ▶ Shock absorption with mechanical shocks.

Mode of operation

Fluids are almost incompressible and therefore cannot store pressure energy. Hydro-pneumatic accumulators use the compressibility of a gas for fluid storage. The nitrogen used must at least comply with cleanliness class 4.0:

N₂ 99.99 vol.%

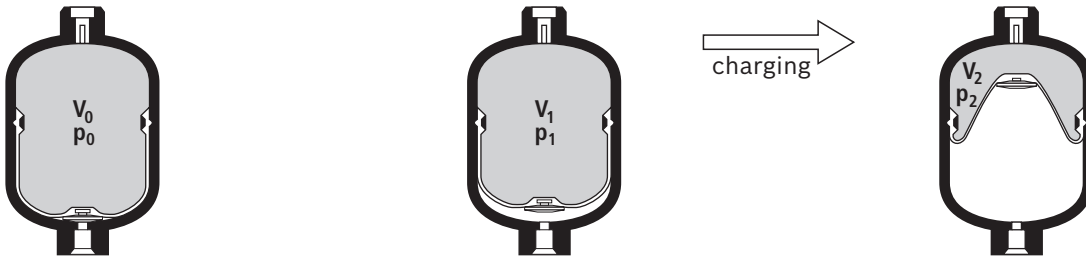

Calculation

Pressures

For calculation of an accumulator, the following pressures play a respective role:

- p_0 = Preset gas pressure at room temperature and drained fluid chamber
- p_{0T} = Preset gas pressure at operating temperature
- p_1 = Minimum operating over-pressure
- p_2 = Maximum operating over-pressure
- t_{max} = Maximum operating temperature

In order to achieve the best utilization of the accumulator volume possible as well as a long life cycle, compliance with the following values is recommended:

$$p_0, t_{max} \approx 0.9 p_1 \quad (1)$$

The highest hydraulic pressure should not exceed four times the filling pressure, as otherwise too much stress will be put on the elasticity of the diaphragm, resulting in too great a compression change with strong gas heating.

The life cycle of the diaphragm is the higher the smaller the difference between p_1 and p_2 is. However, the operating ratio of the maximum accumulator capacity will also be reduced accordingly.

Diaphragm accumulator

$$p_2 \leq 4 \cdot p_0 \quad (2)$$

On request

$$p_2 \leq 8 \cdot p_0$$

Notice:

To achieve an increased pressure ratio ($p_0 : p_2 > 1 : 4$) in the accumulator, a filler can be installed on the gas side of the accumulator.

This way, the usable gas volume V_1 is decreased while the diaphragm is protected against inadmissible deformation.

Calculation

Oil volume

According to the pressures $p_0 \dots p_2$, the gas volumes $V_0 \dots V_2$ will result.

In this process, V_0 simultaneously is the nominal volume of the accumulator.

The available oil volume ΔV corresponds to the difference of the gas volumes V_1 and V_2 :

$$\Delta V \leq V_1 - V_2$$

The gas volume variable within a pressure differential is determined by the following equations:

- For an **isothermal state change of gases**, i.e. when the change of the gas cushion happens so slowly as to leave sufficient time for a complete heat exchange between the nitrogen and its environment, therefore keeping the temperature constant, the following applies:

$$p_0 \cdot V_0 = p_1 \cdot V_1 = p_2 \cdot V_2 \quad (4.1)$$

Calculation diagram

For graphic determination, the formulas (4.1) and (4.2) are converted into diagrams on pages 9 and 10. Depending on the task, the available oil volume, the accumulator size or the pressures can be determined.

Correction factor K_i and K_a

The equations (4.1) and (4.2) apply to ideal gases only. The behavior of real gases, however, will show considerable variation at operating pressures above 200 bar which will have to be accounted for by correction factors. These can be taken from the following diagrams. The correction factors the ideal sampling volume ΔV is to be multiplied with lie within a range of 0.6 ... 1.

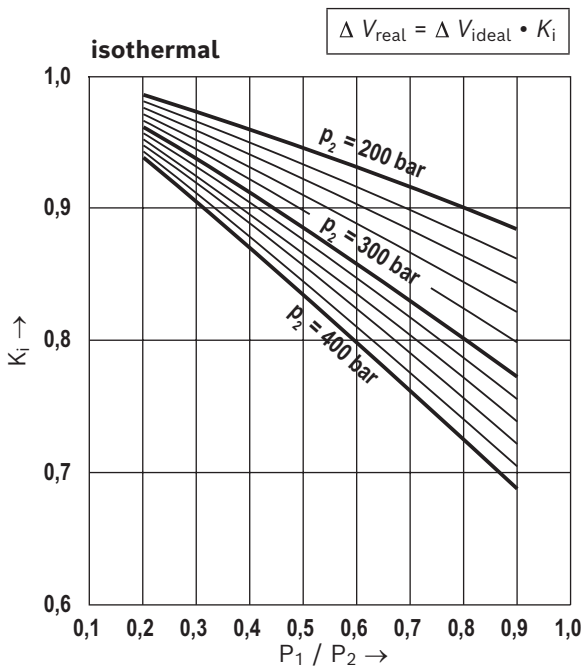

- For an **adiabatic state change**, i.e. a quick change of the gas cushion accompanied by a temperature change of the nitrogen, the following applies:

$$p_0 \cdot V^{\chi_0} = p_1 \cdot V^{\chi_1} = p_2 \cdot V^{\chi_2} \quad (4.2)$$

χ = Ratio of the specific gas heats (adiabatic exponent), for nitrogen = 1.4

In practice, state changes rather follow adiabatic laws. Often charging is isothermal and discharge is adiabatic.

Considering the equations (1) and (2), ΔV is between 50% and 70% of the nominal accumulator volume. The following applies as a guiding principle:

$$V_0 = 1.5 \dots 3 \times \Delta V \quad (5)$$

Application of calculation diagrams

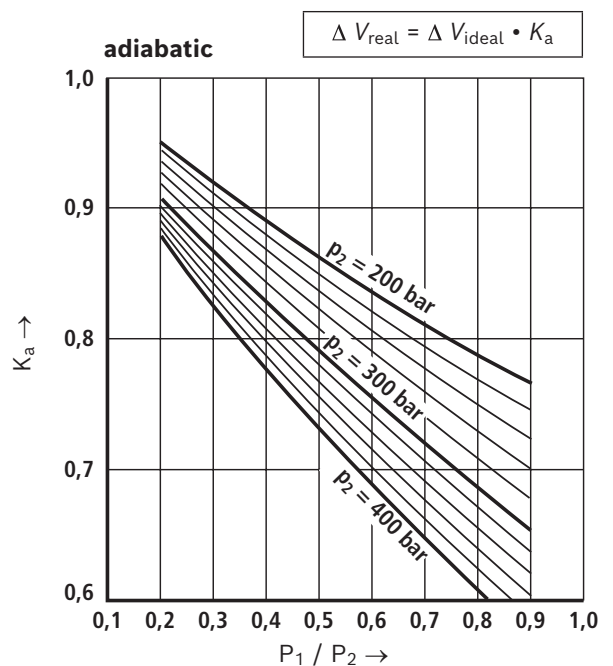
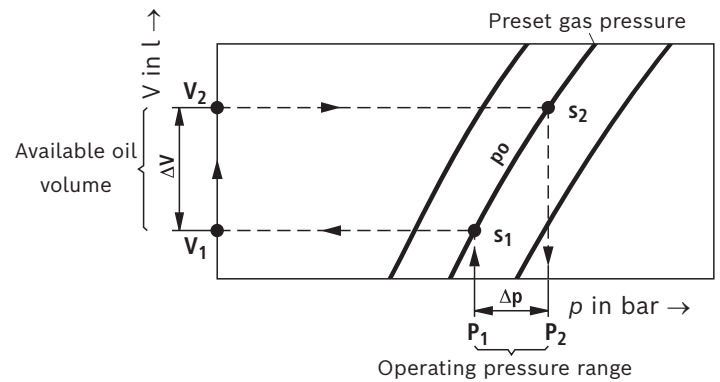

Characteristic curves

Isothermal state changes $p_0 = 1$ to 90 bar

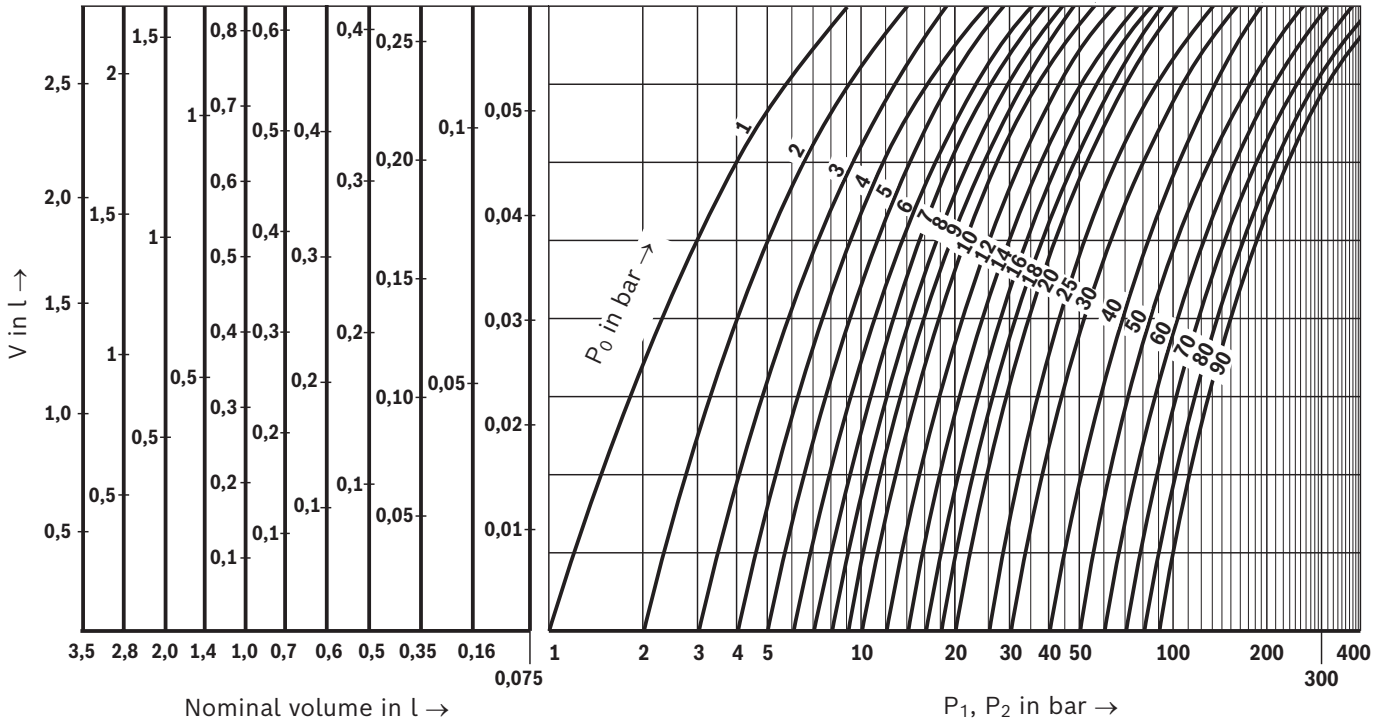

Isothermal state changes $p_0 = 100$ to 250 bar

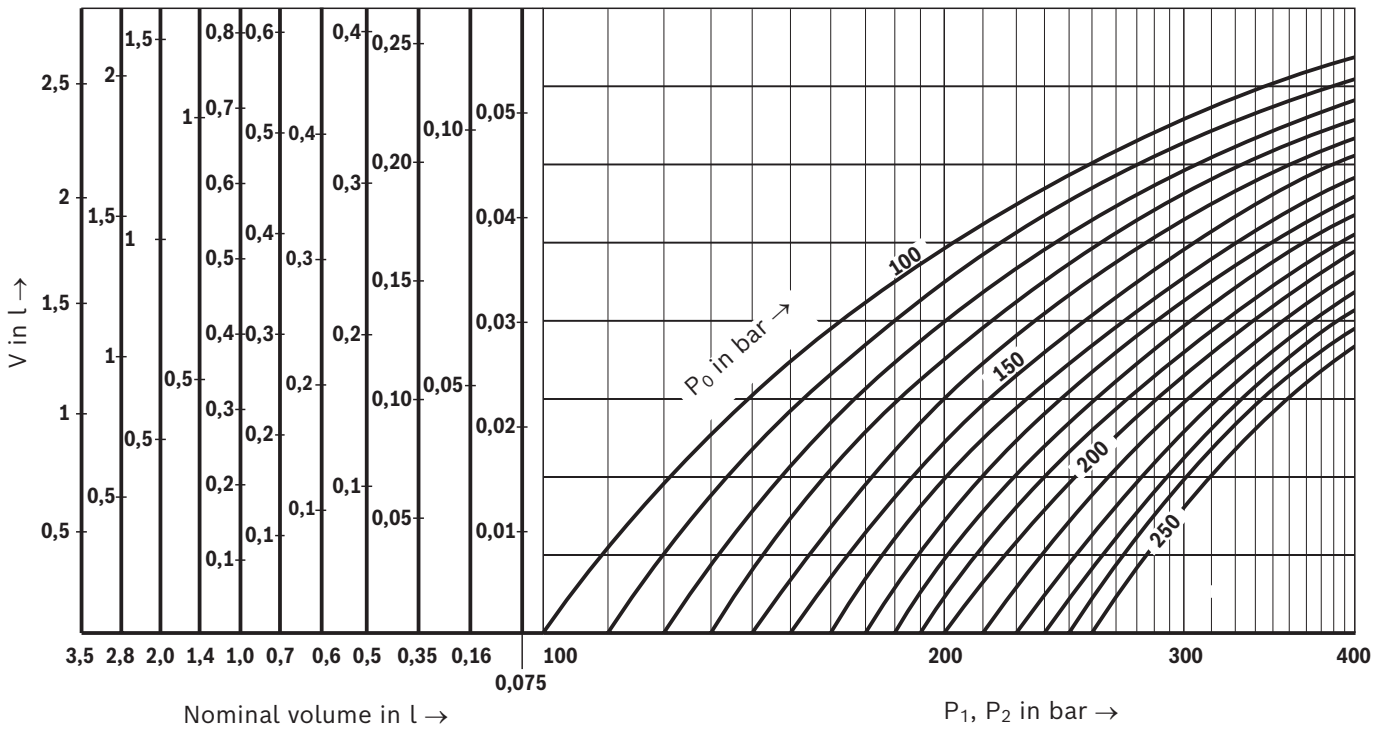

Characteristic curves

Adiabatic state changes $p_0 = 1$ to 90 bar

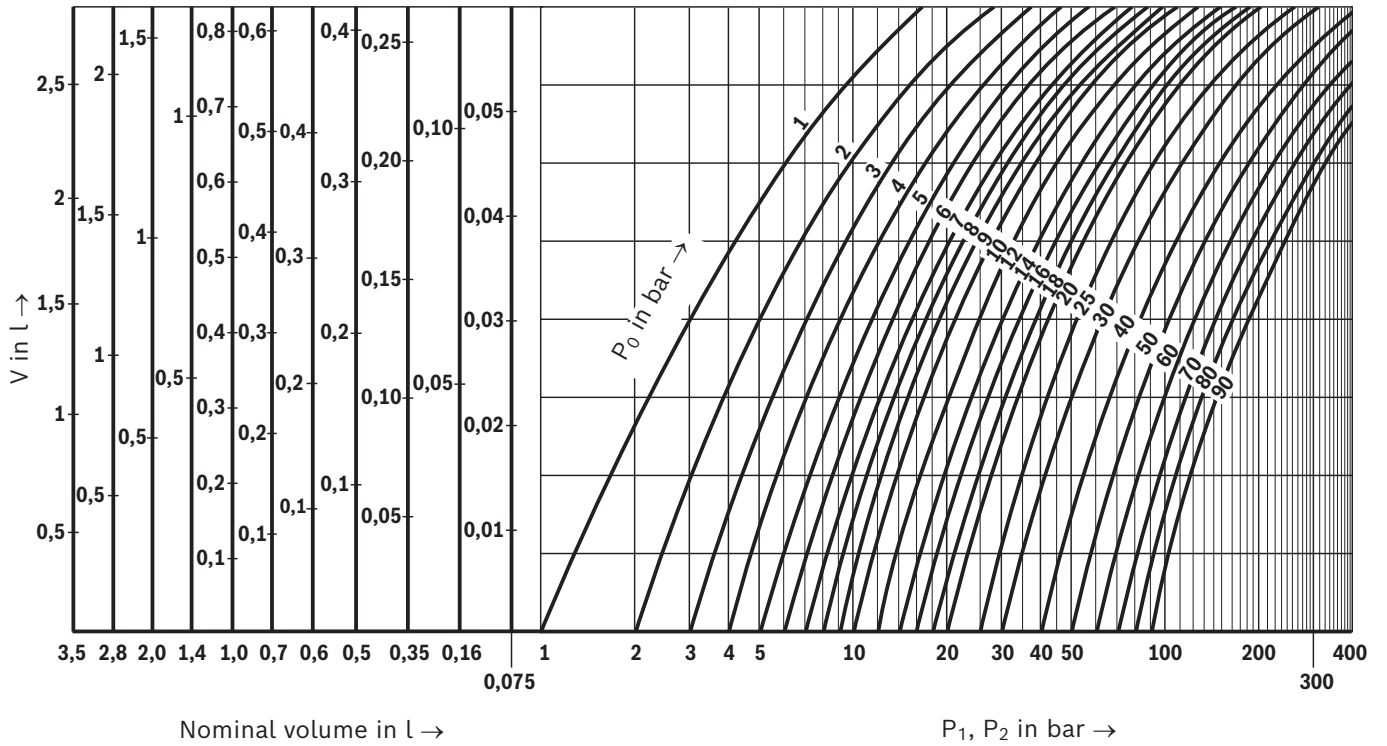

Adiabatic state changes $p_0 = 100$ to 250 bar

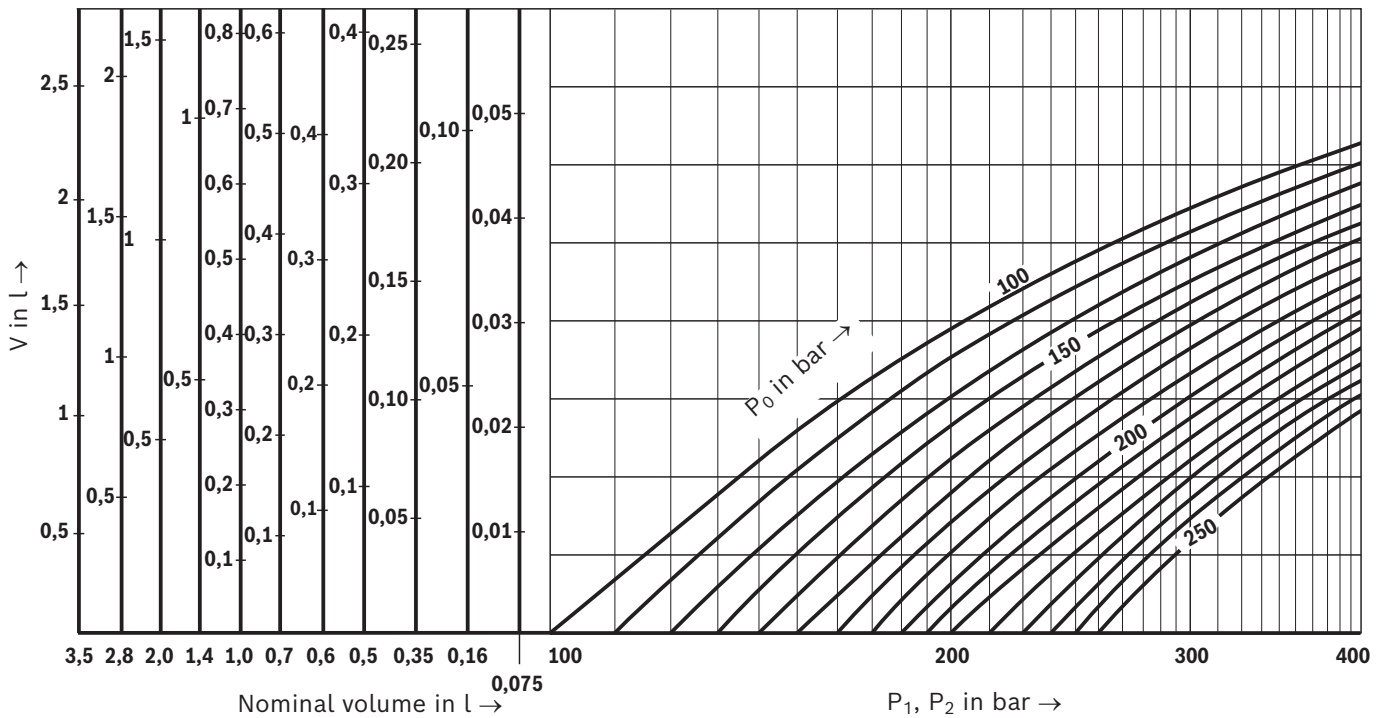

Dimensions: Total overview
(dimensions in mm)

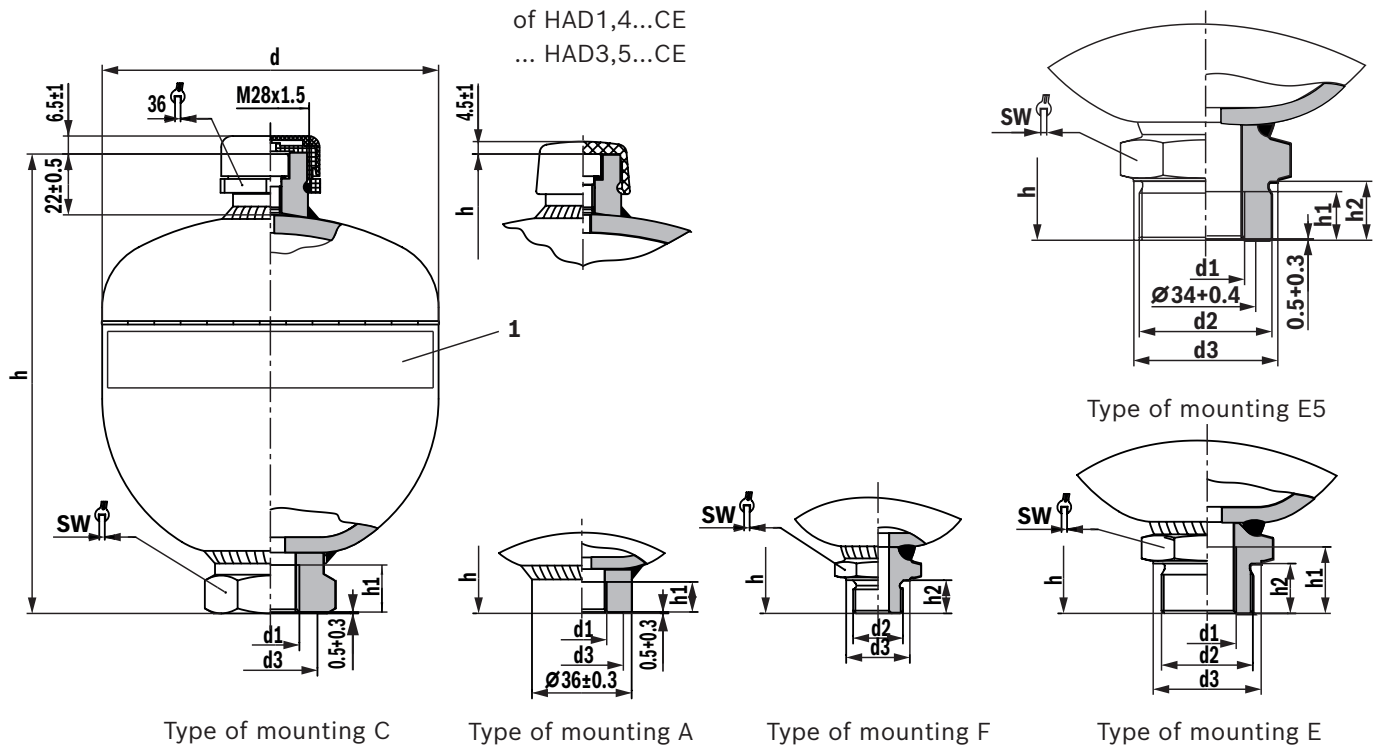

1 Labeling

Volume/pressure/ series	Port size	Type of mounting	h	h1	h2	d	d1	d2	d3	SW	Weight [kg]
0.075-250-1X	G04	C	110.5±1.5	14min.	-	Ø64+0.3	G1/2	-	Ø29+0.4	32	~0.9
	Z04	F	112±1.5	-	12±0.2	Ø64+0.3	-	M14x1.5	Ø19±0.2	19	~0.7
0.16-250-1X	Z06	A	114±1.5	14min.	-	Ø75+0.3	M18x1.5	-	Ø30+0.4	-	~1.0
	G04	C	119±1.5	14min.	-	Ø75+0.3	G1/2	-	Ø29+0.4	32	~0.9
	Z06	F	123±1.5	-	12±0.2	Ø75+0.3	-	M18x1.5	Ø23±0.2	27	~0.9
0.35-160-1X	Z06	A	130±1.5	14min.	-	Ø92.5+0.3	M18x1.5	-	Ø30+0.4	-	~1.3
	G04	A	130±1.5	14min.	-	Ø92.5+0.3	G1/2	-	Ø34+0.4	-	~1.3
0.35-210-1X	Z06	C	136±1.5	14min.	-	Ø92.5+0.3	M18x1.5	-	Ø30+0.4	41	~1.4
	G04	C	136±1.5	17min.	-	Ø92.5+0.3	G1/2	-	Ø34+0.4	41	~1.4
0.35-250-1X	G04	C	141±1.5	17min.	-	Ø95+0.3	G1/2	-	Ø34+0.4	41	~1.7
0.5-160-1X	Z06	C	149±1.5	14min.	-	Ø103+0.3	M18x1.5	-	Ø30+0.4	41	~1.6
	Z06	A	143±1.5	14min.	-	Ø103+0.3	M18x1.5	-	Ø30+0.4	-	~1.5
	G04	A	143±1.5	14min.	-	Ø103+0.3	G1/2	-	Ø34+0.4	-	~1.6
0.5-250-2X	Z06	C	151±1.5	14min.	-	Ø106.7+0.3	M18x1.5	-	Ø30+0.4	41	~2.1
	G04	C	151±1.5	17min.	-	Ø106.7+0.3	G1/2	-	Ø34+0.4	41	~2.1
0.6-330-1X	G04	C	170±1.5	17min.	-	Ø110+0.3	G1/2	-	Ø34+0.4	-	~2.9

Dimensions: Total overview
(dimensions in mm)

Volume/pressure/ series	Port size	Type of mounting	h	h1	h2	d	d1	d2	d3	SW	Weight [kg]
0.7-100-1X	G04	C	161±1.5	14min.	-	Ø117+0.3	G1/2	-	Ø34+0.4	41	~1.7
	G04	E	172±1.5	24min.	18±0.2	Ø117+0.3	G1/2	M33x1.5	Ø39±0.3	41	~2.0
0.7-180-1X	G04	C	166±1.5	17min.	-	Ø121.5+0.3	G1/2	-	Ø34+0.4	41	~2.6
	Z06	C	166±1.5	14min.	-	Ø121.5+0.3	M18x1.5	-	Ø30+0.4	41	~3.0
	Z06	A	160±1.5	14min.	-	Ø121.5+0.3	M18x1.5	-	Ø30+0.4	-	~2.6
	G04	A	160±1.5	14min.	-	Ø121.5+0.3	G1/2	-	Ø34+0.4	-	~2.6
0.7-210-1X	G04	E	177±1.5	24min.	18±0.2	Ø121.5+0.3	G1/2	M33x1.5	Ø39±0.3	41	~2.6
	G04	C	166±1.5	14min.	-	Ø121.5+0.3	G1/2	-	Ø34+0.4	41	~2.7
0.7-250-1X	G04	C	169±1.5	17min.	-	Ø123.6+0.3	G1/2	-	Ø34+0.4	41	~3.2
	Z06	A	163±1.5	14min.	-	Ø123.6+0.3	M18x1.5	-	Ø30+0.4	-	~2.9
	G04	A	163±1.5	14min.	-	Ø123.6+0.3	G1/2	-	Ø34+0.4	-	~2.9
	G04	E	180±1.5	24min.	18±0.5	Ø168.5±1.5	G1/2	M33x1.5	Ø39±0.2	41	~3.1
0.7-350-2X	G04	C	173±1.5	14min.	-	Ø128.5+0.6	G1/2	-	Ø34+0.4	41	~4.0
	G04	E	184±1.5	24min.	18±0.2	Ø128.5+0.6	G1/2	M33x1.5	Ø39±0.3	41	~4.0
1.0-200-1X	G04	C	180±1.5	14min.	-	Ø136.2+0.3	G1/2	-	Ø34+0.4	41	~3.5
	Z08	C	180±1.5	17min.	-	Ø136.2+0.3	M22x1.5	-	Ø34+0.4	41	~3.5
	G04	E	191±1.5	24min.	18±0.2	Ø136.2+0.3	G1/2	M33x1.5	Ø39±0.3	41	~3.6
1.0-250-1X	G04	C	181±1.5	17min.	-	Ø137+0.3	G1/2	-	Ø34+0.3	41	~3.8
1.4-140-1X	G04	C	191±1.5	14min.	-	Ø147+0.6	G1/2	-	Ø34+0.4	41	~4.3
	G04	E	202±1.5	24min.	18±0.2	Ø147+0.6	G1/2	M33x1.5	Ø39±0.3	41	~4.2
1.4-250-1X	G04	C	195±1.5	14min.	-	Ø152+0.6	G1/2	-	Ø34+0.4	41	~5.5
	Z08	C	195±1.5	14min.	-	Ø152+0.6	M22x1.5	-	Ø34+0.4	41	~5.5
	G04	E	206±1.5	24min.	18±0.2	Ø152+0.6	G1/2	M33x1.5	Ø39±0.3	41	~5.5
1.4-350-2X	G04	C	198±1.5	14min.	-	Ø156+0.6	G1/2	-	Ø34+0.4	41	~6.8
	G04	E	209±1.5	24min.	18±0.2	Ø156+0.6	G1/2	M33x1.5	Ø39±0.3	41	~6.8
2.0-100-1X	G04	C	240±2	17min.	-	Ø144.7+0.5	G1/2	-	Ø34+0.4	41	~4.1
	Z08	C	240±2	14min.	-	Ø144.7+0.5	M22x1.5	-	Ø34+0.4	41	~4.1
	G05	E5	258±1.5	16min.	20±0.2	Ø144.7+0.5	G3/4	M45x1.5	Ø49±0.3	50	~4.3
2.0-250-1X	G04	C	251±1.5	14min.	-	Ø156+0.6	G1/2	-	Ø34+0.4	41	~8.6
	Z08	C	251±1.5	14min.	-	Ø156+0.6	M22x1.5	-	Ø34+0.4	41	~8.6
	G05	C	251±0.5	16min.	-	Ø156+0.6	G3/4	-	Ø33+0.4	41	~8.6
	G05	E5	269±1.5	16min.	20±0.5	Ø156+0.6	G3/4	M45x1.5	Ø49±0.3	50	~8.9
2.0-350-2X	G05	C	251±1.5	14min.	-	Ø156+0.6	G3/4	-	Ø33+0.4	41	~9.5
	G05	E5	269±1.5	16min.	20±0.5	Ø156+0.6	G3/4	M45x1.5	Ø49±0.3	50	~8.9
2.8-70-1X	G04	C	266±2	17min.	-	Ø160+0.3	G1/2	-	Ø34+0.4	41	~10.0
	Z08	C	266±2	17min.	-	Ø160+0.3	M22x1.5	-	Ø34+0.4	41	~10.0
2.8-250-2X	Z08	C	267±1.5	17min.	-	Ø168.5±1.5	M22x1.5	-	Ø34+0.4	41	~8.0
	G05	C	267±1.5	16min.	-	Ø168.5±1.5	G3/4	-	Ø33+0.4	41	~8.3
	G05	E5	286±1.5	16min.	20±0.5	Ø168.5±1.5	G3/4	M45x1.5	Ø49±0.3	50	~8.6
2.8-350-2X	G05	C	271±1.5	16min.	-	Ø175±0.6	G3/4	-	Ø34+0.4	41	~11.5
	G05	E5	290±1.5	16min.	20±0.5	Ø175±0.6	G3/4	M45x1.5	Ø49±0.3	50	~11.8
3.5-55-2X	G05	C	312±1.5	16min.	-	Ø168.5±1.5	G3/4	-	Ø33+0.4	41	~9.6
3.5-250-2X	G05	C	312±1.5	16min.	-	Ø168.5±1.5	G3/4	-	Ø33+0.4	41	~9.6
	G05	E5	331±1.5	16min.	20±0.5	Ø168.5±1.5	G3/4	M45x1.5	Ø49±0.3	50	~9.8

Dimensions: Preferred types: 0.075 to 1 l
(dimensions in mm)

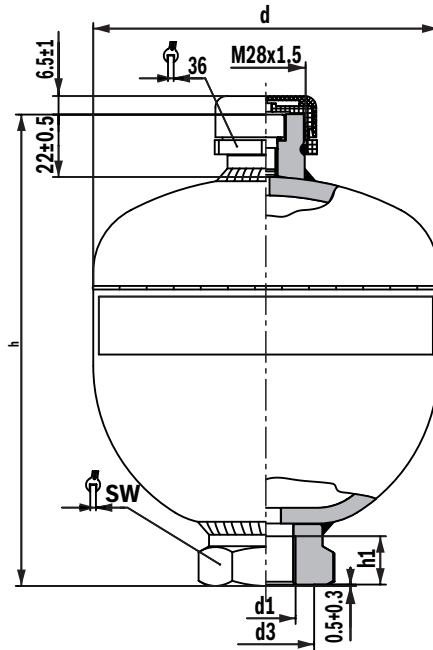

Ordering code/type	Volume/ pressure/series	Material number	h	h1	d	d1	d3	SW	Weight [kg]
HAD0,075-250-1X/OG04C-1N111-BA	0.075-250-1X	R901359266	110.5±1.5	14min.	Ø64+0.3	G1/2	Ø29+0.4	32	~0.9
HAD0,16-250-1X/OG04C-1N111-BA	0.16-250-1X	R901359268	119±1.5	14min.	Ø75+0.3	G1/2	Ø29+0.4	32	~0.9
HAD0,35-250-1X/OG04C-1N111-BA	0.35-250-1X	R901461019	141±1.5	17min.	Ø95+0.3	G1/2	Ø34+0.4	41	~1.7
HAD0,5-250-2X/OG04C-1N111-BA	0.5-250-2X	R901463743	151±1.5	17min.	Ø106.7+0.3	G1/2	Ø34+0.4	41	~2.1
HAD0,6-330-1X/OG04C-1N111-BA	0.6-330-1X	R901445989	170±1.5	17min.	Ø110+0.3	G1/2	Ø34+0.4	41	~2.9
HAD0,7-250-1X/OG04C-1N111-BA	0.7-250-1X	R901463745	169±1.5	17min.	Ø123.6+0.3	G1/2	Ø34+0.4	41	~3.0
HAD1,0-250-1X/OG04C-1N111-BA	1.0-250-1X	R901461023	181±1.5	17min.	Ø137+0.3	G1/2	Ø34+0.4	41	~3.8

Dimensions: Preferred types: 1.4 to 3.5 l
(dimensions in mm)

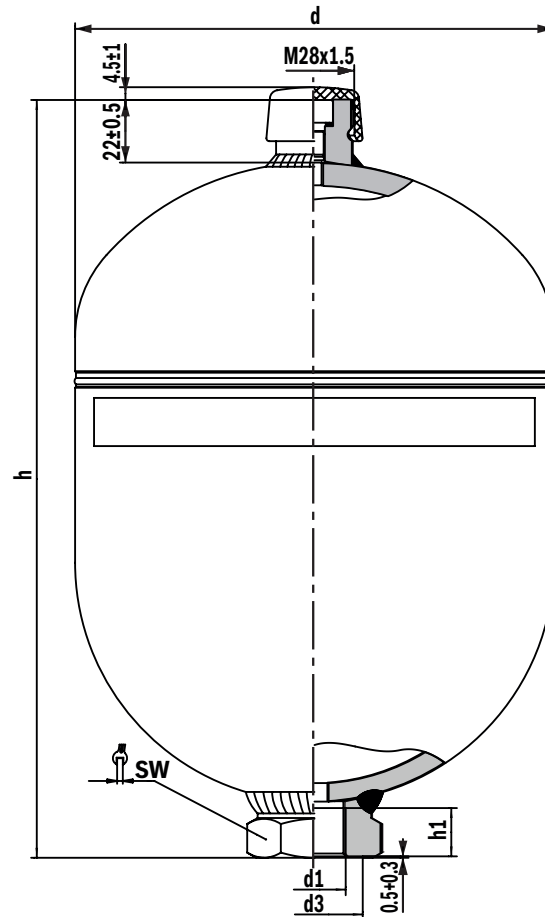

Ordering code/type	Volume/ pressure/series	Material number	h	h1	d	d1	d3	SW	Weight [kg]
HAD1,4-250-1X/OG04C-1N111-CE	1.4-250-1X	R901463746	195±1.5	14min.	Ø152+0.6	G1/2	Ø34+0.4	41	~5.5
HAD2,0-250-1X/OG05C-1N111-CE	2.0-250-1X	R901463747	251±1.5	16min.	Ø156+0.6	G3/4	Ø33+0.4	41	~8.6
HAD2,8-250-2X/OG05C-1N111-CE	2.8-250-2X	R901463748	267±1.5	16min.	Ø168.5±1.5	G3/4	Ø33+0.4	41	~8.3
HAD3,5-250-2X/OG05C-1N111-CE	3.5-250-2X	R901463764	312±1.5	16min.	Ø168.5±1.5	G3/4	Ø33+0.4	41	~9.6

Accessories

(dimensions in mm)

Accumulator adapter for accumulator shut-off blocks type ABZSS

Please select the matching type according to data sheet 50131.

Accumulator D1	Block D2	ØD3	Material number
M 22 x 1.5	M 33 x 2	12	1 533 359 012
M 18 x 1.5		8	1 533 359 013
G 1/2 ISO 228		8	1 533 359 034

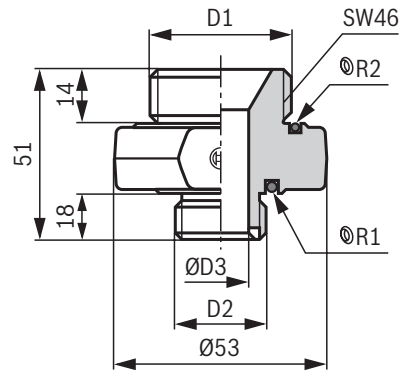

Mounting clamp, see selection table

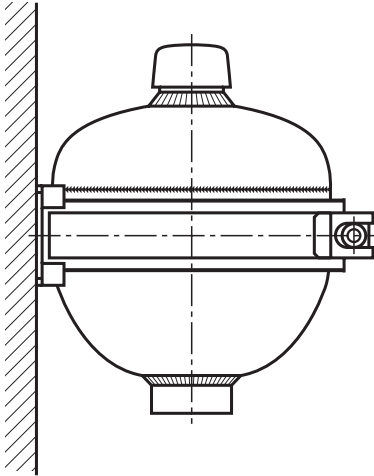

Type	Material number	Denomination
HAD0,075-250-1X	-	
HAD0,16-250-1X	-	
HAD0,35-160-1X	1531316017	MOUNTING CLAMP 92-97 MM
HAD0,35-210-1X		
HAD0,35-250-1X		
HAD0,5-160-1X	1531316018	MOUNTING CLAMP 101-111 MM
HAD0,5-250-2X		
HAD0,6-330-1X	1531316021	MOUNTING CLAMP 110-120 MM
HAD0,7-100-1X		
HAD0,7-180-1X	1531316015	MOUNTING CLAMP 119-128 MM
HAD0,7-210-1X		
HAD0,7-250-1X		
HAD0,7-350-2X	R901073992	MOUNTING CLAMP 128-136 MM
HAD1,0-200-1X	1531316019	MOUNTING CLAMP 135-145 MM
HAD1,0-250-1X		
HAD1,4-140-1X	1531316016	MOUNTING CLAMP 145-155 MM
HAD1,4-250-1X		
HAD1,4-350-2X	R901526730	MOUNTING CLAMP 155-163 MM
HAD2,0-100-1X	1531316016	MOUNTING CLAMP 145-155 MM
HAD2,0-250-1X		
HAD2,0-350-2X	R901526730	MOUNTING CLAMP 155-163 MM
HAD2,8-70-1X		
HAD2,8-250-2X	1531316022	MOUNTING CLAMP 160-170 MM
HAD2,8-350-2X	1531316020	MOUNTING CLAMP 170-180 MM
HAD3,5-55-2X	1531316022	MOUNTING CLAMP 160-170 MM
HAD3,5-250-2X		

Accessories

(dimensions in mm)

Mounting kit for mounting type E and E5

consisting of mounting bracket and hexagon nut

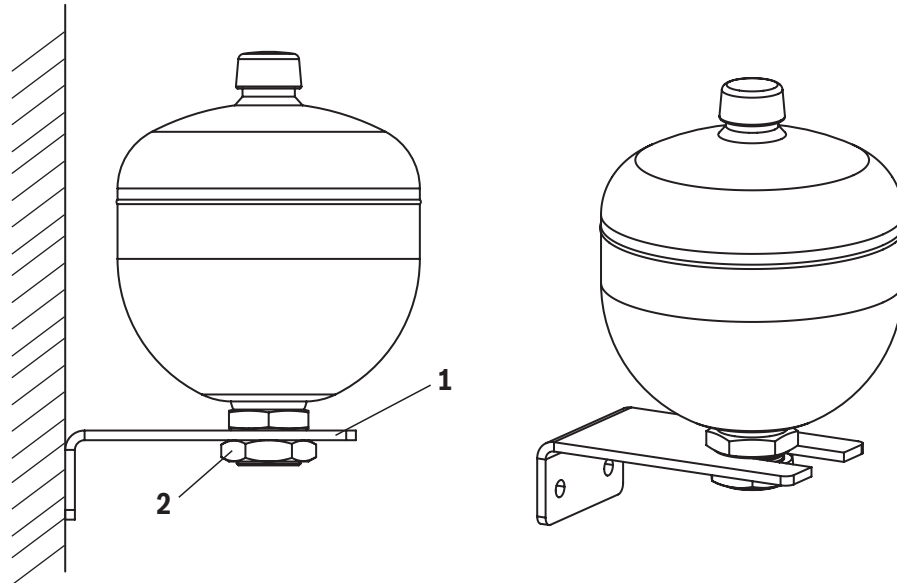

Position	Designation	Material number
1+2	MOUNTING KIT ZN10060-K 0,7-1,4 Liter	R901273946
1+2	MOUNTING KIT ZN10060-K 2,0-3,5 Liter	R901273947
2	HEXAGON NUT M33X1,5X11-CM-FE-ZN-&	R901285712
2	HEXAGON NUT M45X1,5X13-CM-FE-ZN-	R901280785

Warning sign ^{2) 3)}

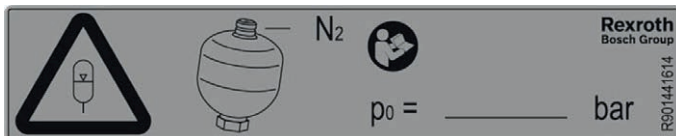

Warning sign	Material number
► for diaphragm accumulator (HAD) Size: 100 mm x 20 mm Color: yellow	R901441614

²⁾ The warning sign can be directly attached at the accumulator as of nominal volume 0.35 l.

³⁾ The warning sign is available for order as of a batch size of 100 units.

Spare protective cap for gas valve ⁴⁾



Protective cap HAD	Material number
► for all diaphragm accumulators (HAD) Color: red	R913002007

⁴⁾ The protective cap is available for order as of a batch size of 10 units.

Accessories

(dimensions in mm)

Charging and test device



Measurement case	Material number
► for diaphragm accumulator (HAD)	0538103012
► for bladder and diaphragm accumulator (HAB/HAD)	0538103014
► Spare parts:	
- Case (without contents)	R901079781
- Charging and test valve HAB	0538103005
- Charging and test valve HAD	0538103006
- Pressure gauge 0 ... 250 bar	1537231001
- Hose l = 2.5 m with cap nut	1530712005

(D)

Supplemental parts (separate order)		Material number
Pressure gauge 0 ... 25 bar		R900033955
Pressure gauge 0 ... 60 bar		1537231002
Pressure gauge 0 ... 400 bar		1537231005
Adapter for nitrogen bottle to cap nut	(F)	1533391010
	(GB)	1533391011
	(USA)	1533391012
	(KR)	1533391013
	(J)	R900216133
Hose l = 5 m with cap nut	(RUS)	1533391015
	(D)	1530712006

Dimensions: Charging and test valve

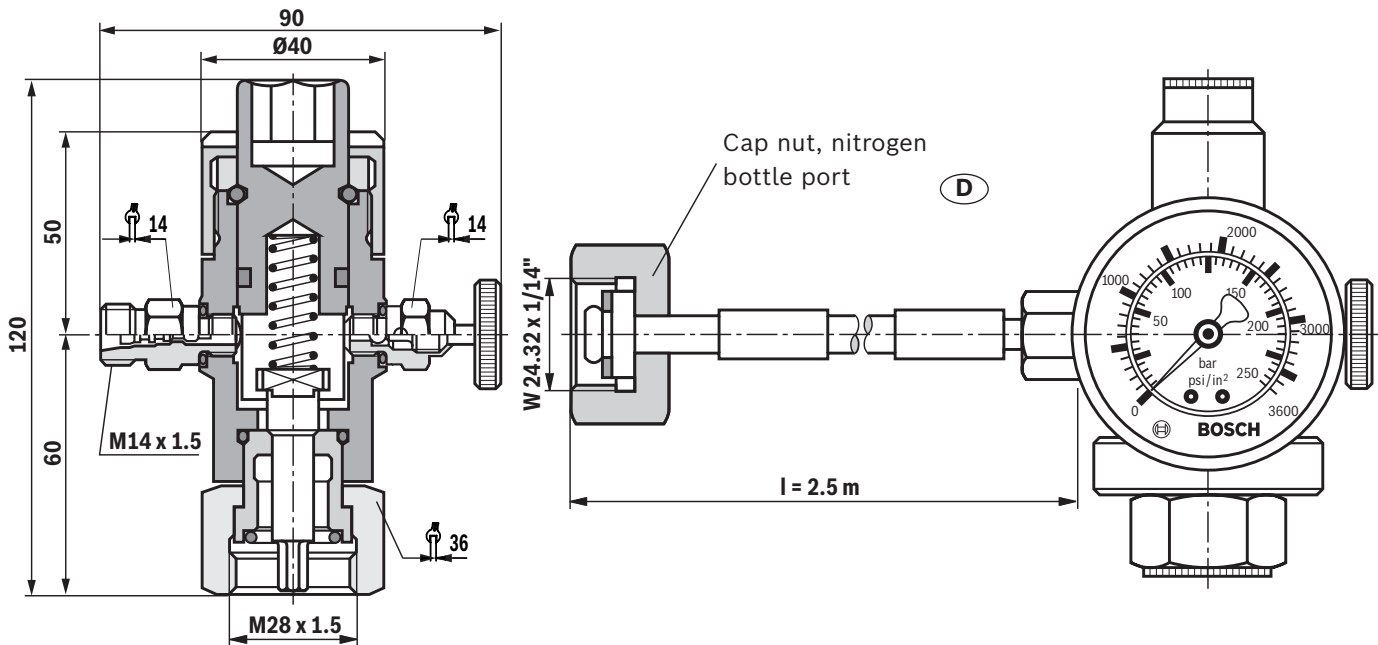

Accessories
(dimensions in mm)

Adapter for nitrogen bottle to cap nut

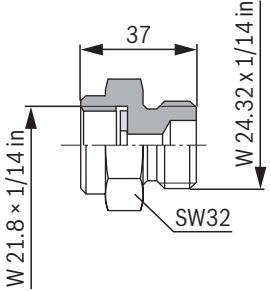
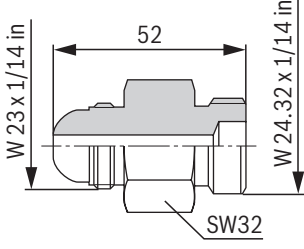
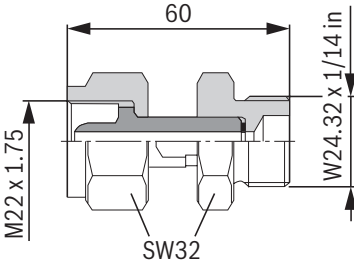
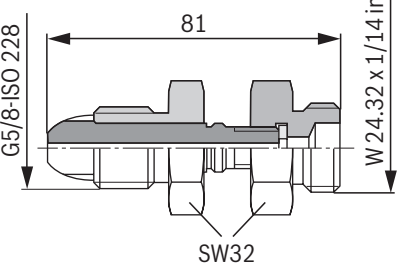
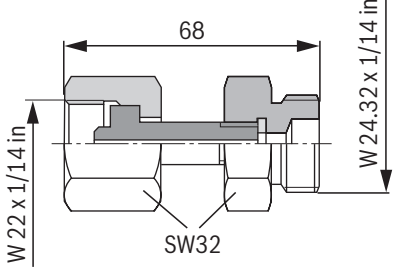
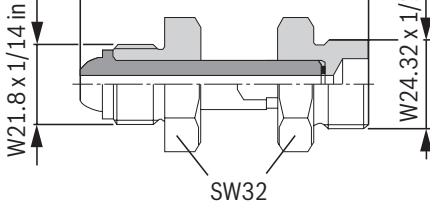
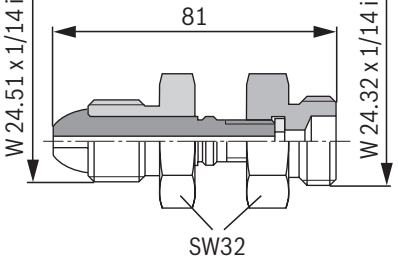
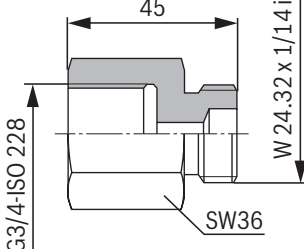
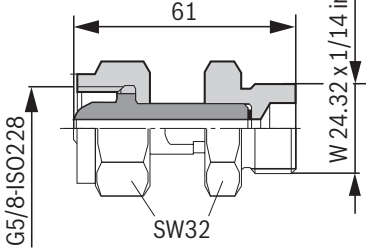
<p>Material number: 1533391010</p> 	<p>Material number: 1533391013</p> 	<p>Material number: R900034782</p> 
<p>Material number: 1533391011</p> 	<p>Material number: R900216133</p> 	<p>Material number: R900708208</p> 
<p>Material number: 1533391012</p> 	<p>Material number: 1533391015</p> 	<p>Material number: R901070776</p> 

Accessories**Adapter for nitrogen bottle to cap nut**

Country ¹⁾	Material number								
	1533391010	1533391011	1533391012	1533391013	R900216133	1533391015	R900034782	R900708208	R901070776
Brazil		x							
Bulgaria		x							
China									x
France	x								
Greece		x							
United Kingdom		x							
India		x							
Italy								x	
Japan					x				
Canada			x						
North Korea				x					
South Korea				x					
Malaysia		x							
Mexico	x								
Romania	x								
Russia						x			
Spain		x							
Saudi Arabia	x								
Singapore		x							
Taiwan							x		
Turkey		x							
USA			x						

¹⁾ Other countries upon request

Important notices

Intended use

Rexroth diaphragm accumulators type HAD..-1X/2X are intended for the set-up of hydraulic drive systems in stationary mechanical engineering and plant construction. In mobile applications or applications in which acceleration forces are applied to the diaphragm accumulator during intended use, its use is permitted only following release by the competent Rexroth product manager. Please contact technical sales for this.

Rexroth diaphragm accumulators type HAD..-1X/2X are not intended for private use.

Project planning information

Diaphragm accumulators have to be safely and permanently fastened to the machine or system using mounting elements. The fastening is intended to keep the oil port tension-free. Particularly, no tension forces or static or dynamic inertia forces should be applied to the oil port. Thermal expansion of the supporting structure and vibrations originating from the environment should be considered in the selection of suitable mounting points.

Safety instructions for hydro-pneumatic accumulators

The machine end-user is required to enclose operating instructions RE 50150-B for the machine or system and the CE Declaration of Conformity for containers > 1 liters. General information for hydro-pneumatic accumulators in hydraulic system can be found in DIN EN ISO 4413. Keep all documents included in the delivery in a safe place. They will be required by the expert in recurring tests.

Safety equipment

Notice:

Hydro-pneumatic accumulators have to be secured against operation outside of the admissible limits according to Pressure Equipment Directive 2014/68/EU.

Legal provisions

Hydro-pneumatic accumulators are pressure vessels and subject to the application national provisions and/or regulations valid at the place of installation. In Germany, the Ordinance on Industrial Safety and Health (BetrSichV) applies. In special applications, additional regulations for shipbuilding, aircraft construction or mining may apply.

Authorized persons

According to Ordinance on Industrial Safety and Health (BetrSichV), only authorized persons may carry out tests. Authorized persons are such persons having obtained the required expert knowledge through professional training, experience and recent professional activity.

In order not to exceed the maximum operating pressure, Bosch Rexroth recommends the use of an accumulator shut-off block type ABZSS according to data sheet 50131.

Commissioning

Installation conditions

Charging pressure

Diaphragm accumulators are usually delivered in condition ready for operation. The charging pressure (p_0) is engraved on the accumulator housing.

Charging gas

Hydro-pneumatic accumulators must only be filled with nitrogen of class 4.0, pure N₂ content of 99.99 vol.%.

Admissible operating temperature

In "**standard version**", Rexroth hydro-pneumatic accumulators are suitable for operating temperatures of -15...+80 °C.

For deviating temperatures, please contact Bosch Rexroth.

Installation position

Diaphragm accumulators may be installed in any installation position.

Above the gas valve, an installation space of 200 mm must be provided for the charging and test device.

Mounting

When mounting the accumulator, make sure that possible forces, such as the ones created by vibrations or acceleration specific for that application, are absorbed safely. When using several mounting points, avoid stress caused by operational, elastic deformations or temperature expansions.

Bosch Rexroth offers corresponding mounting clamps (see page 14).

Further information

Operating instructions in different languages and declarations of conformity for tank sizes of 1.4 to 3.5 liters are included in the scope of delivery of the product.

Operating instructions

Language	Operating instructions
German	RD 50150-B
English	RE 50150-B
Spanish	RS 50150-B
French	RF 50150-B
Italian	RI 50150-B
Russian	R-RS 50150-B
Czech	R-CZ 50150-B
Polish	R-PL 50150-B
Chinese	RC 50150-B
Turkish	RT 50150-B

CE Declarations of Conformity

in German, English, French

Type	Declaration of conformity
HAD up to 1.0	-
HAD1,4 - HAD3,5	RA83506544